

Smart Electronic Pressure Transmitter Type BCN1

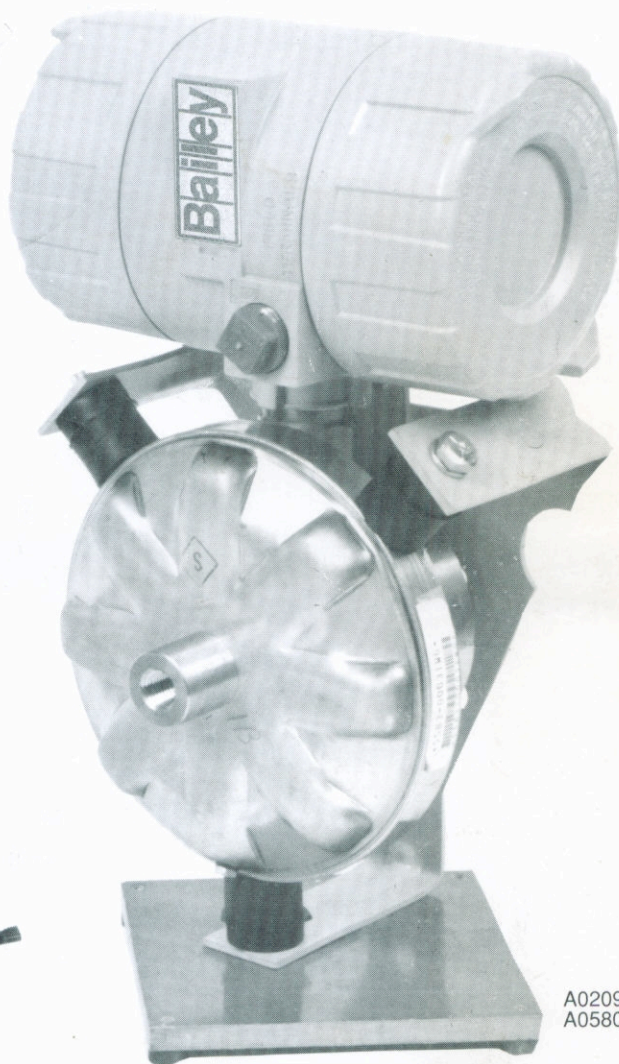
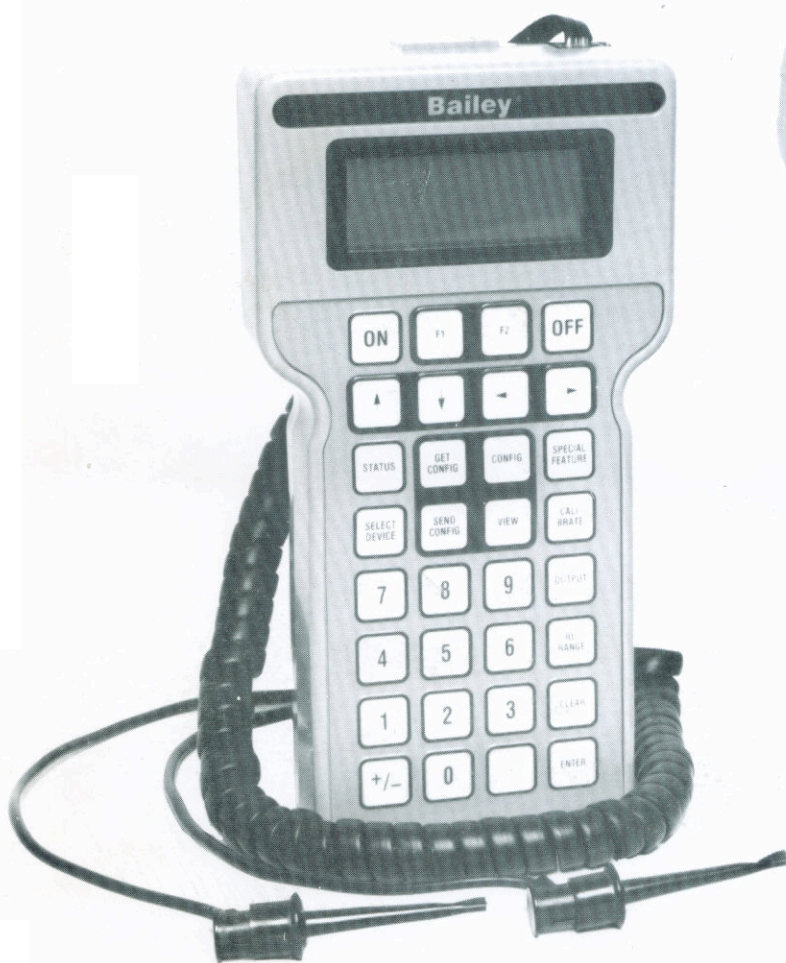

A0209
A0580

WARNING notices as used in this manual apply to hazards or unsafe practices which could result in personal injury or death.

CAUTION notices apply to hazards or unsafe practices which could result in property damage.

NOTES highlight procedures and contain information which assist the operator in understanding the information contained in this manual.

WARNING

INSTRUCTION MANUALS

DO NOT INSTALL, MAINTAIN OR OPERATE THIS EQUIPMENT WITHOUT READING, UNDERSTANDING AND FOLLOWING THE PROPER **Bailey Controls** INSTRUCTIONS AND MANUALS, OTHERWISE INJURY OR DAMAGE MAY RESULT.

RADIO FREQUENCY INTERFERENCE

MOST ELECTRONIC EQUIPMENT IS INFLUENCED BY RADIO FREQUENCY INTERFERENCE (RFI). CAUTION SHOULD BE EXERCISED WITH REGARD TO THE USE OF PORTABLE COMMUNICATIONS EQUIPMENT IN THE AREA AROUND SUCH EQUIPMENT. PRUDENT PRACTICE DICTATES THAT SIGNS SHOULD BE POSTED IN THE VICINITY OF THE EQUIPMENT CAUTIONING AGAINST THE USE OF PORTABLE COMMUNICATIONS EQUIPMENT.

POSSIBLE PROCESS UPSETS

MAINTENANCE MUST BE PERFORMED ONLY BY QUALIFIED PERSONNEL AND ONLY AFTER SECURING EQUIPMENT CONTROLLED BY THIS PRODUCT. ADJUSTING OR REMOVING THIS PRODUCT WHILE IT IS IN THE SYSTEM MAY UPSET THE PROCESS BEING CONTROLLED. SOME PROCESS UPSETS MAY CAUSE INJURY OR DAMAGE.

AVERTISSEMENT

MANUELS D'OPERATION

NE PAS METTRE EN PLACE, REPARER OU FAIRE FONCTIONNER CE MATERIEL SANS AVIOR LU, COMPRIS ET SUIVIES LES INSTRUCTIONS REGLIMENTAIRES DE **Bailey Controls** TOUTE NEGLIGENCE A CET EGARD POURRAIT ETRE UNE CAUSE D'ACCIDENT OU DE DEFAILLANCE DU MATERIEL.

PERTURBATIONS DE LA FREQUENCE RADIOPHONIQUE

LA PLUPART DES EQUIPEMENTS ELECTRONIQUES SONT SENSIBLES AUX PERTURBATIONS DE LA FREQUENCE RADIO. DES PRECAUTIONS DEVRONT ETRE PRISES LORS DE L'UTILISATION DE MATERIEL DE COMMUNICATION PORTATIF. LA PRUDENCE EXIGE QUE LES PRECAUTIONS A PREDRE DANS CE CAS SOIENT SIGNALEES AUX ENDROITS VOULOUS DANS VOTRE USINE.

PERTES PROCEDE RENVERSEMENTS

L'ENTRETIEN DOIT ETRE ASSURE PAR UN PERSONNEL QUALIFIE ET EN CONSIDERATION DE L'ASPECT SECURITAIRE DES EQUIPEMENTS CONTROLES PAR CE PRODUIT. L'ADJUSTEMENT ET/OU L'EXTRACTION DE CE PRODUIT LORSQU'IL EST INSERE A UN SYSTEME ACTIF PEUT OCCASIONNER DES A-COUPS AU PROCEDE CONTROLE. SUR CERTAINS PROCEDES, CES A-COUPS PEUVENT EGALEMENT OCCASIONNER DES DOMMAGES OU BLESSURES.

NOTICE

The information contained in this document is subject to change without notice.

Bailey Controls Company, its affiliates, employees, and agents, and the authors of and contributors to this publication specifically disclaim all liabilities and warranties, express and implied (including warranties of merchantability and fitness for a particular purpose), for the accuracy, currency, completeness, and/or reliability of the information contained herein and/or for the fitness for any particular use and/or for the performance of any material and/or equipment selected in whole or part with the user of/or in reliance upon information contained herein. Selection of materials and/or equipment is at the sole risk of the user of this publication.

This document contains proprietary information which is protected by copyright. All rights are reserved. No part of this document may be photocopied or reproduced without the prior written consent of **Bailey Controls Company**.

Preface

This document includes operation, calibration, maintenance and troubleshooting instructions for the Bailey Type BCN1 Smart Electronic Pressure Transmitter.

Table Of Contents

INTRODUCTION	1-1
Introduction	1-1
Equipment Description	1-1
Equipment Application	1-1
Instruction Content	1-1
How to Use This Manual	1-1
Glossary of Terms and Abbreviations	1-2
Nomenclature	1-2
Performance/Functional Specifications	1-3
Physical Characteristics	1-3
Options and Accessories	1-4
Certification	1-4
DESCRIPTION AND OPERATION	2-1
Introduction	2-1
Functional Operation	2-1
Physical Operation	2-1
Transducer Assembly	2-1
Electronics Assembly	2-1
Communication	2-2
Temperature Compensation	2-2
Diagnostics	2-2
Transmitter Software Functions	2-3
INSTALLATION	3-1
Introduction	3-1
Unpacking and Inspection	3-1
Location Considerations	3-1
Setup and Physical Installation	3-1
Connecting Piping	3-3
General	3-3
Flow Measurement	3-3
Pressure Piping	3-4
Wiring Connections	3-4
Point-to-Point Mode	3-4
Field Bus Mode	3-4
Grounding	3-5
Hazardous Locations	3-5
CALIBRATION	4-1
Initial Calibration	4-1

Checkout (Calibration Check)	4-1
Temperature Compensation	4-1
Changing Calibration	4-2
OPERATING PROCEDURES	5-1
Introduction	5-1
Operator Interface	5-1
Configuration Procedure	5-1
Transmitter Address	5-1
ID Tag	5-1
Output Type	5-1
Output Action	5-1
Damping Action	5-1
Primary Engineering Units	5-1
Primary Lower and Upper Range Values	5-2
Secondary (Flow) Engineering Units	5-2
Secondary (Flow) Lower and Upper Range Values	5-2
Local LCD Setup	5-2
Start-up and Failure Conditions	5-2
Get Configuration Procedure	5-2
Monitor Input Procedure	5-3
Monitor Output Procedure	5-3
Monitor Secondary Engineering Units	5-3
Monitor Transducer Temperature Procedure	5-3
Fix Output Procedure	5-3
Transmitter Status Check Procedure	5-3
Special Operating Considerations	5-3
Configuration Lockout Procedure	5-3
TROUBLESHOOTING	6-1
Introduction	6-1
Error Messages and Corrective Action	6-1
MAINTENANCE	7-1
Introduction	7-1
Maintenance Schedule	7-1
Amplifier Housing	7-1
Transducer Assembly	7-1
Flange	7-1
Transmitter Rezero	7-1
REPAIR/REPLACEMENT	8-1
Introduction	8-1
Procedures	8-1
General	8-1
Transducer Check	8-1
Smart BCN Transmitter	8-1
Conventional and Smart BC Upgraded Transmitter	8-1
Amplifier Assembly Boards	8-1
Amplifier Boards Check	8-1
LCD Board Check	8-2
Replacing Amplifier Housing Components	8-2
Replacing the Transducer Assembly	8-4

SUPPORT SERVICES	9-1
Introduction	9-1
Replacement Parts	9-1
APPENDIX A	A-1

List Of Illustrations

FIGURE 1 – Square Root Output	1-5
FIGURE 2 – Load Range	1-5
FIGURE 3 – Type BCN1 Smart Transmitter	2-1
FIGURE 4 – Type BCN Smart Transmitter Electronics Diagram	2-2
FIGURE 5 – Point-to-Point Wiring	2-3
FIGURE 6 – Field Bus Arrangement	2-4
FIGURE 7 – Type BCN1 Smart Transmitter External and Mounting Dimensions	3-2
FIGURE 8 – Connecting Piping for Gas Flow Measurement	3-3
FIGURE 9 – Typical Calibration Setup	4-2
FIGURE 10– Sample Temperature Compensation Data Label	4-3
FIGURE 11– Lockout Jumper (J1) Locations and Positions on the Microcomputer Board	5-3
FIGURE 12– Troubleshooting Flow Chart	6-3
FIGURE 13– Amplifier Assembly (Exploded View)	8-3
FIGURE 14– Jumper Wire Locations and Positions on Input Board	8-4
FIGURE 15– Type BCN1 Transducer Assembly	8-5
FIGURE 16– Type BCN1 Smart Transmitter Replacement Parts	9-3
FIGURE A1– Loop Drawing	A-3
FIGURE A2 – CSA Certified I.S. Entity Loops	A-3

List Of Tables

TABLE 1 – Error Messages	6-2
TABLE 2 – Troubleshooting Chart	6-4

List Of Effective Pages

Total number of pages in this manual is 46, consisting of the following:

PAGE NO.	CHANGE NO.
ii Through viii	Original
1-1 Through 1-5	Original
2-1 Through 2-4	Original
3-1 Through 3-5	Original
4-1 Through 4-3	Original
5-1 Through 5-3	Original
6-1 Through 6-5	Original
7-1	Original
8-1 Through 8-5	Original
9-1 Through 9-5	Original
A-1 Through A-4	Original

When an update is received, insert the latest changed pages and dispose of the superseded pages.

NOTE: On an updated page, the changed text or table is indicated by a vertical bar in the outer margin of the page adjacent to the changed area. A changed figure is indicated by a vertical bar in the outer margin next to the figure caption. The date the update was prepared will appear under the page number.

Safety Summary

GENERAL WARNINGS

NAMEPLATE RATINGS

Do not, at any time, exceed the ratings listed on the nameplate. (Page 3-1)

On ne doit en aucune circonstance dépasser les valeurs nominales figurant sur la plaque d'identification. (Page 3-1)

SYSTEM MAINTENANCE

System maintenance must be performed only by qualified personnel and only after securing equipment controlled by the circuit. Altering or removing components from an active circuit may upset the process being controlled. (Page 7-1)

L'entretien du système doit être effectué par des personnes compétentes et uniquement à partir du moment où les éléments contrôlés par le circuit ont été isolés. Le fait d'enlever ou d'altérer les composants d'un circuit sous tension peut perturber le processus contrôlé. (Page 7-1)

SUBSTITUTION OF COMPONENTS

Substitution of components may impair suitability for use in hazardous locations. (Page A-1, A-4)

La substitution de composants peut rendre l'émetteur inadéquat à l'utilisation dans un environnement dangereux. (Page A-1, A-4)

HAZARDOUS LOCATIONS

The equipment used herein may be used only in those classes of hazardous locations identified on the nameplate.

L'équipement décrit par cette notice ne peut être installé que dans les emplacements spécifiés sur la plaque signalétique de l'appareil.

SPECIFIC WARNINGS

WARNING

The output of this equipment changes to a fixed value during start-up and transmitter detected failure conditions. These values must be selected by the user to ensure safe operation. (Page 5-2)

Disconnecting/reconnecting wiring or repairing the transmitter is not considered normal operation. These operations should only be done if power has been removed from all wiring or if the flammable atmosphere is known not to be present. (Page A-1)

Intrinsic safety is dependent upon the components used in the transmitter. Any substitution of components may impair the intrinsic safety. (Page A-2)

Explosionproof/dust-ignition proof installation and intrinsically safe installations in Class II or III hazardous locations require that the assembly be kept tight while circuits are live unless the location is known to be non-hazardous at the time. (Page A-4)

CAUTION

Do not remove or force amplifier assembly completely out of housing. This will cause damage to pin connectors at P1, P2 and the sensor lead connector. (Page 8-2)

AVERTISSEMENT

La sortie de cet appareil adopte une valeur fixe lors de la mise sous tension et de certaines conditions de pannes. Ces valeurs fixes doivent être sélectionnées par l'utilisateur pour assurer une sécurité. (Page 5-2)

Le débranchement ou le rebranchement des fils ainsi que la réparation du transmetteur n'entrent pas dans les procédures normales. Si l'atmosphère est inflammable, on ne doit effectuer les étapes ci-dessus que si l'alimentation a été interrompue. (Page A-1)

La sécurité intrinsèque dépend des composantes utilisées dans l'émetteur. Toute substitution de composante pourrait nuire à cette sécurité intrinsèque. (Page A-2)

En ce qui concerne l'installation anti-explosion et anti-ignition provoquée par la poussière dans des endroits de Classe II ou III, il est indispensable que l'assemblage soit tenu étanche pendant que les circuits sont électrifiés, à moins que cet endroit ne présente aucun danger à ce moment-là. (Page A-4)

ATTENTION

Nes pas retirer complètement l'assemblage des composants de son boîtier. Ceci endommagerait les broches et les connexions P1 et P2 ainsi que le connecteur des fils de la sonde. (Page 8-2)

Introduction

INTRODUCTION

This Product Instruction is intended to assist personnel with operation, calibration, troubleshooting and maintenance procedures of the Bailey Type BCN1 Smart Electronic Transmitter. The BCN measures pressure and may be user-configured to provide a polled digital process variable signal (field bus mode). It can also be used to provide a 4 to 20 mA process variable signal (point-to-point mode).

EQUIPMENT DESCRIPTION

The Bailey Type BCN1 Smart Electronic Transmitter measures low range differential pressure. It may be user-configured to provide a polled digital process variable signal (field bus mode) or a 4 to 20 mA process variable signal (point-to-point mode). The BCN transmits a signal proportional to the differential pressure or the flow. The electronics package uses the latest microcomputer technology, allowing the user to calibrate and troubleshoot the transmitter from either a local or remote location. The Bailey Type STT02 Smart Transmitter Terminal can communicate with the Smart Transmitter. Configuration, readout, and other interactions with the transmitter operate by this communication method. An optional liquid crystal display is also available when local transmitter output indication is necessary.

EQUIPMENT APPLICATION

The BCN1 Electronic Pressure Transmitter is designed to measure low range differential pressure. The BCN1 measures gas or vapor pressure spans of 0.3 inches H₂O up to 6.0 inches H₂O (0.07 to 1.49 kPa).

INSTRUCTION CONTENT

This document includes the following sections:

INTRODUCTION – This section provides a description of this Instruction Manual; its sections and their uses, along with a brief description of the BCN1. Also included in this section are instructions on how to use this document, glossary of terms and abbreviations, product identification (Nomenclature) and performance specifications.

DESCRIPTION AND OPERATION – Describes the operation of principal components of the BCN1. Also

covered in this section are communication techniques and the diagnostic capabilities afforded to the user.

INSTALLATION – This section gives information on the various tasks associated with the installation of the transmitter. Detailed procedures are provided for unpacking, location considerations, physical installation, piping suggestions and wiring instructions.

CALIBRATION – Identifies the calibration methods of the unit. This section also provides calibration check procedures and explains temperature compensation of the BCN Transmitter.

OPERATING PROCEDURES – This section addresses start-up procedures, configuration of the BCN using STT02 handheld Smart Transmitter Terminal, and the procedures that make the unit operational.

TROUBLESHOOTING – Provides the user steps that aid in solving operating difficulties that can occur. Tables are included that list corrective action that relate to error messages appearing on the STT02 display. Also included is a troubleshooting flow chart.

MAINTENANCE – Includes maintenance information as it pertains to the transducer assembly.

REPAIR/REPLACEMENT – This section covers procedures involved in replacing components of the Type BCN1 Pressure Transmitter and steps used to check component operational status.

HOW TO USE THIS MANUAL

It is important for safety and operating reasons that this product instruction be read and understood completely before installing or completing any tasks or procedures associated with operation.

The sections of this instruction book are sequentially arranged as they relate to initial start-up; from **Unpacking** to **Repair/Replacement Procedures**. After initial start-up, the instruction may then be referred to as needed by section.

Introduction

GLOSSARY OF TERMS AND ABBREVIATIONS

ANSI – American National Standards Institute.

EEPROM – Electrically Erasable Programmable Read Only Memory. A type of non-volatile memory that is programmed and erased electrically.

EPROM – Erasable Programmable Read Only Memory. This memory holds the microcomputer's operating program.

FINAL INSTALLATION – The final position or plane in which the transmitter will be mounted for operation.

NON-VOLATILE MEMORY – Memory that retains programmed information; such as configuration and calibration parameters, even when power is removed.

SEDIMENT – A solid material deposit that settles in a liquid or gas. Such deposits can cause blockage in piping.

TRANSDUCER – A device that takes an input, such as pressure, and converts the output into some other form, such as voltage.

NOMENCLATURE

BCN1 SMART ELECTRONIC LOW DIFFERENTIAL TRANSMITTER										
Pos.	4	5	6	7	8	9	10	11	SMART ELECTRONIC TRANSMITTER	
BCN	<input type="checkbox"/>	<input type="checkbox"/>	<input type="checkbox"/>	<input type="checkbox"/>	<input type="checkbox"/>	<input type="checkbox"/>	<input type="checkbox"/>	<input type="checkbox"/>		
	1	1 2	6	1 2	1	3	5 6	0	TYPE Low Range (15 psi maximum static pressure)	
									SPAN 0.3 to 3 in. H ₂ O 0.6 to 6 in. H ₂ O	
									DIAPHRAGM/TRIM MATERIAL AM350/316L Stainless Steel	
									FILL FLUID Silicone Fluid Fluorinated Oil	
									FLANGE ADAPTER/VENT/DRAIN PLUG MATERIALS 316 Stainless Steel/316 Stainless/None	
									O-RING/BOLTING MATERIAL *VITON®/300 Series Stainless Steel	
									INTEGRAL METER None With LCD Meter	
									MOUNTING BRACKET SUPPLIED 0 2-Inch U-Bolt	

* Viton® – registered trademark of E.I. du Pont de Nemours.

PERFORMANCE/FUNCTIONAL SPECIFICATIONS (Zero-Based Spans)

Service	Gas or non-condensing vapor.
Accuracy	$\pm 0.10\%$ of calibrated span. (Includes effects of linearity, hysteresis, repeatability, and dead band.)
Stability	$\pm 0.10\%$ of upper range limit for six months.
Long-Term Stability	Drift less than $\pm 0.20\%$ of upper range limit for 12 months.
Output Signal	Analog Output: 4 to 20 mA user-selectable for linear, square root or function generator output. (See Figure 1 for square root output.) Digital Output: Digital process variable is reported up to ten times per second for linear, square root or function generator.
Output Current Limiting	25 mA.
Supply Voltage	13 to 42 V dc.
Power Supply Effect	Point-to-Point Mode: 0.005% of span per volt. Field Bus Mode: No effect.
Loop Load Limits	See Figure 2.
Static Pressure Limit	15 psi (103 kPa).
Static Pressure Effect	Zero error: BCN11: $\pm 0.12\%$ of upper range limit/psi (6.9 kPa). BCN12: $\pm 0.06\%$ of upper range limit/psi (6.9 kPa). Span error: $\pm 0.1\%$ of upper range limit/3 psig (21 kPa).
Overpressure Limits	15 psi (103 kPa). Full vacuum to overpressure limit on either or both sides will not damage the transmitter. Any zero shift due to overpressure condition should be calibrated out.
Mounting Position Effect	No span effect. No zero effect in plane of diaphragm. Maximum of 2 in. H ₂ O (0.49 kPa) zero shift in any other plane; can be calibrated out.
Damping	Continuously adjustable from 0.00 to 32.00 seconds.
Temperature Limits	Operating: From -13° to $+185^{\circ}\text{F}$ (-25° to $+85^{\circ}\text{C}$), transmitter will operate within specifications; from -40° to $+212^{\circ}\text{F}$ (-40° to $+100^{\circ}\text{C}$) transmitter will operate without damage to the unit. Storage: -58° to $+212^{\circ}\text{F}$ (-50° to $+100^{\circ}\text{C}$).

Unit with Optional LCD Meter	Operating: $+32^{\circ}$ to $+122^{\circ}\text{F}$ (0° to $+50^{\circ}\text{C}$). Temperatures outside of this range will cause the display to go blank until temperature returns to operating range. Temperatures outside of this range will not adversely affect transmitter operation. Storage: -5° to $+158^{\circ}\text{F}$ (-21° to $+70^{\circ}\text{C}$).
Temperature Effects	From -13° to $+185^{\circ}\text{F}$ (-25° to $+85^{\circ}\text{C}$). Total error: $\pm 0.25\%$ of upper range limit for any temperature changes of not more than $\pm 50^{\circ}\text{F}$ ($\pm 28^{\circ}\text{C}$). (Reference conditions of 80°F [27°C]).
Elevation/Suppression	Maximum zero elevation is 1000% of calibrated span. Maximum zero suppression is 900% of calibrated span. Neither span nor upper or lower range value may exceed 100% of upper range limit.
RFI Effect	$\pm 1.0\%$ of calibrated span for 20 – 1000 MHz @ 30 V/m field strength.
Turn Down	10:1.
Turn on Time	4 seconds at minimum damping.
Humidity Limits	0 – 100% continuous when covers are properly installed and conduit is sealed.
Response Time (electronics only)	Point-to-point mode: 250 milliseconds. Field bus mode: Process variable reported up to ten times a second.

PHYSICAL CHARACTERISTICS

Amplifier Housing	Housing is a die cast aluminum alloy with less than 1% copper, protected with a chemical resistant polyurethane coating; rated NEMA 4X.
Process Connections	See Figure 7.
Electrical Connections	Test, signal, and grounding terminals are accessible through one of the two 1/2-inch NPT conduit holes provided on opposite sides of the transmitter; unused opening is plugged with a 1/2-inch stainless steel NPT pipe plug.
Materials	Fill Fluid: Silicone or fluorinated oil.
Selection	Process-wetted parts: refer to NOMENCLATURE .
Transmitter Weight	15 lbs. 10 oz. (7.1 kg)

Introduction

OPTIONS AND ACCESSORIES

Material Variations	Refer to NOMENCLATURE .
LCD Meter	(See NOMENCLATURE for selection). Integral circuit board provides 12-digit alphanumeric Liquid Crystal Display (LCD) of transmitter output signal as percent of span or in engineering units (display accurate to 0.1% of span and suitable for calibration of device.) Rotate in 90 degree increments inside cover to yield best viewing orientation. The LCD Meter is also available as an add-on option. Kit No. 258453-1.
3-Valve Manifold	Provides the required valving for flow measurement using differential pressure-producing primary elements; Part No. 6635357-1: Nipple, connection tubing, 90° elbows, and 316SS manifold (Anderson, Greenwood, and Co. MM1VS); Part No. 6635357-2: manifold for oxygen service.
Mounting Bracket	Flat bracket for pipe or wall mounting, Part No. 6634409-1.
Conversion Kit (BC to BCN)	Kit No. 258456-1. This converts any BC transmitter to the BCN transmitter.
BCN Transmitter Terminal	Battery-powered portable communications device; allows the user to remotely configure, calibrate, troubleshoot, or simply verify the operation of a Smart BCN Transmitter. Order by Nomenclature: STT02.
Transient Suppressor	Suppresses switching and lightning induced transients; mounts internally or externally; Part No. 1947359-1.
*Special Cleaning	Transmitter wetted parts are cleaned to remove any trace contaminants including grease and oil.
Tag Options	Part No. 1963318-1: Mylar®, adhesive backed aluminum finish. Part No. 487436-2: Stainless steel, specify wire attached or permanently affixed. Customer may specify 4 lines of 12 upper case characters.

* For Oxygen Service Preparation: Normal practice is to specify fluorinated oil sensor fill fluid (nomenclature item) and special cleaning (accessory item).

SPECIFICATIONS SUBJECT TO CHANGE WITHOUT NOTICE.

CERTIFICATION

Certified by Canadian Standards Association (CSA), Factory Mutual Research (FM), and Standards Association of Australia (SAA) as follows:	
Nonincendive (pending)	
CSA	Class I; Div 2; Groups B-D
FM	Class I; Div 2; Groups C,D
SAA	Zone 2, Ex n, Group IIC
Intrinsically Safe when used with appropriate barriers per Bailey Controls Co. Drawing B222611 (pending)	
CSA	Classes I, II, III; Div 1; Groups A-G, T4
FM	Classes I, II, III; Div 1; Groups A-G, T6
SAA	Zone 0; Ex ia, Group IIC, T6
Explosionproof (flameproof)	
CSA	Class I; Div 1; Groups B-D
*FM	Class I; Div 1; Groups B-D
SAA	Zone 1; Ex d; Group IIB
Dust-ignitionproof	
CSA	Classes II, III; Div 1; Groups E-G
*FM	Classes II, III; Div 1; Groups E-G
SAA	Zone 1; Ex DIP 13 Enclosures IP65

* Approval received.

MYLAR® is a registered trademark of E.I. DuPont de Nemours & Co.

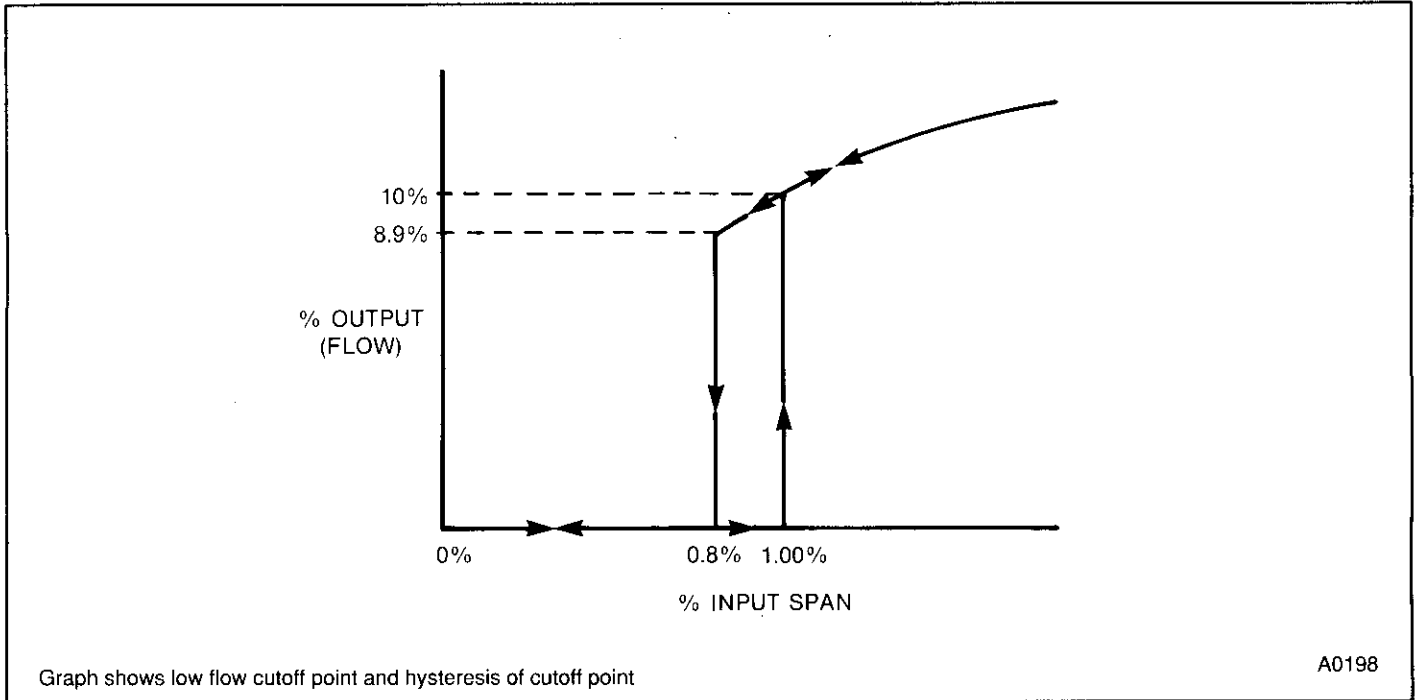

NOTE: Accuracy of square root mode: Below 0.8% of input, the output is forced to 0%. Above 1% of input, accuracy equals the square root if the accuracy stated in the specifications. Example: BCN1 accuracy equals $\pm 0.1\%$, in the square root mode accuracy equals the square root of 0.1.

FIGURE 1 – Square Root Output

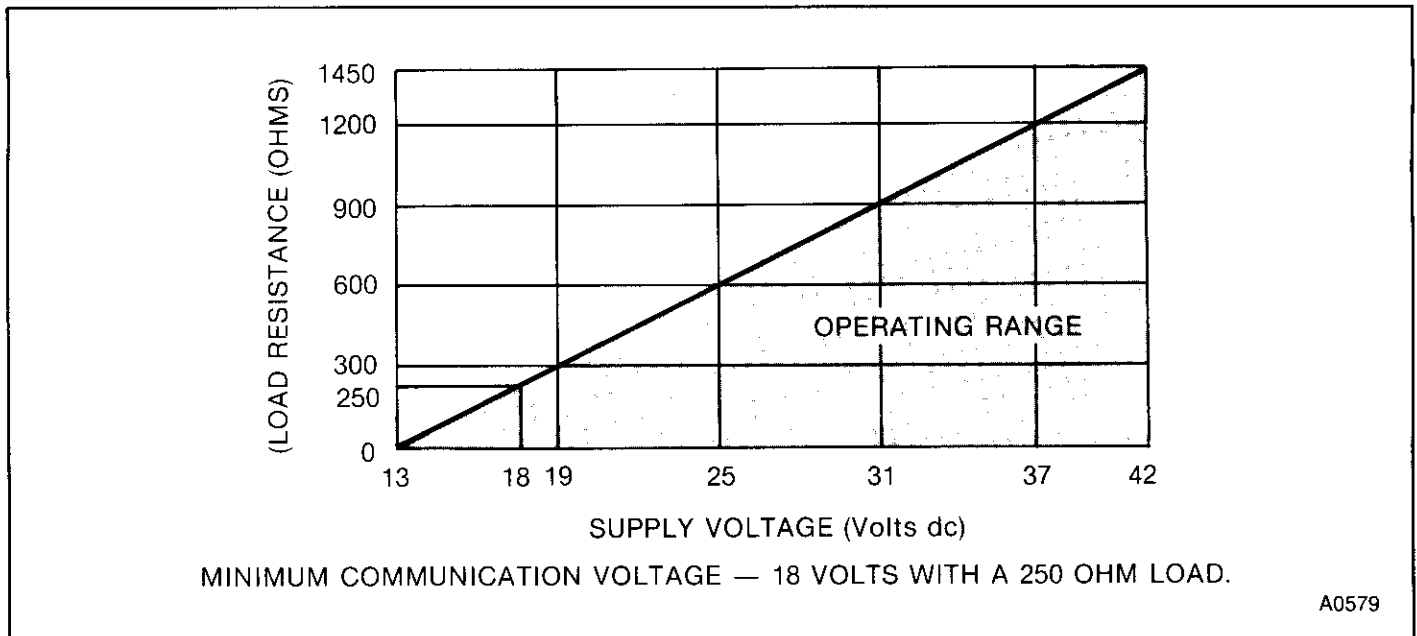

FIGURE 2 – Load Range



Description And Operation

INTRODUCTION

This section of the instruction book describes and explains the BCNI Transmitter; operation of its principal components and the manner in which the user accesses the information gathered by the transmitter.

FUNCTIONAL OPERATION

The Smart Transmitter consists of two major sections: a transducer assembly and an electronics assembly. Together, these components output data for monitoring pressure and flow rate (see Figure 3). The Bailey Type STT02 Smart Transmitter Terminal is available to communicate with the Smart Transmitter.

PHYSICAL OPERATION

Transducer Assembly

The transmitter uses applied pressure to the transducer assembly to effect a change in resistance to a strain gage. Process differential pressure is applied to the transmitter by direct connection to the front of the diaphragm flange ("H", high pressure side). The low pressure connection is on the back of the flange.

A force resulting from the pressure is transmitted to a cantilever beam by rods attached to the diaphragm. The closed bridge strain gage is bonded to the cantilever beam. Deflection of the beam by pressure variations produces an output voltage from the bridge which is directly proportional to the differential pressure.

Electronics Assembly

The electronics assembly is shown in Figure 4 in block form. The output of the strain gage (not shown) goes into a voltage-to-pulse converter. The voltage-to-pulse converter outputs a variable duty cycle pulse. The microcomputer uses inputs from the voltage-to-pulse converter and calculates an output based on the variable duty cycle pulse inputs. The transmitter stores the configured memory in an EEPROM.

The output of the microcomputer goes into an active multiple pole low pass filter. The filter outputs a dc voltage level proportional to the output duty cycle of the pulse input. This dc voltage feeds the output transistor which controls the 4 to 20 mA signal.

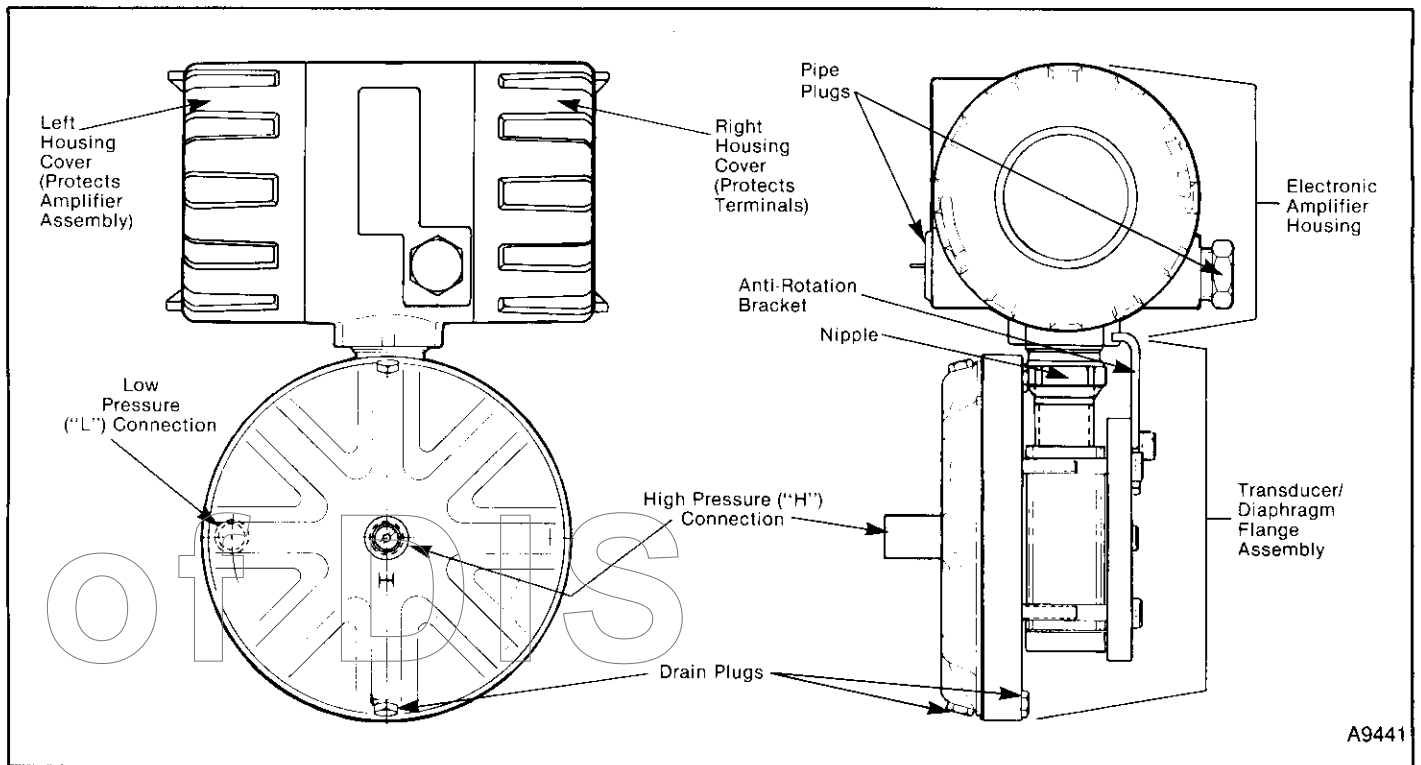

FIGURE 3 – Type BCNI Smart Transmitter

Description and Operation

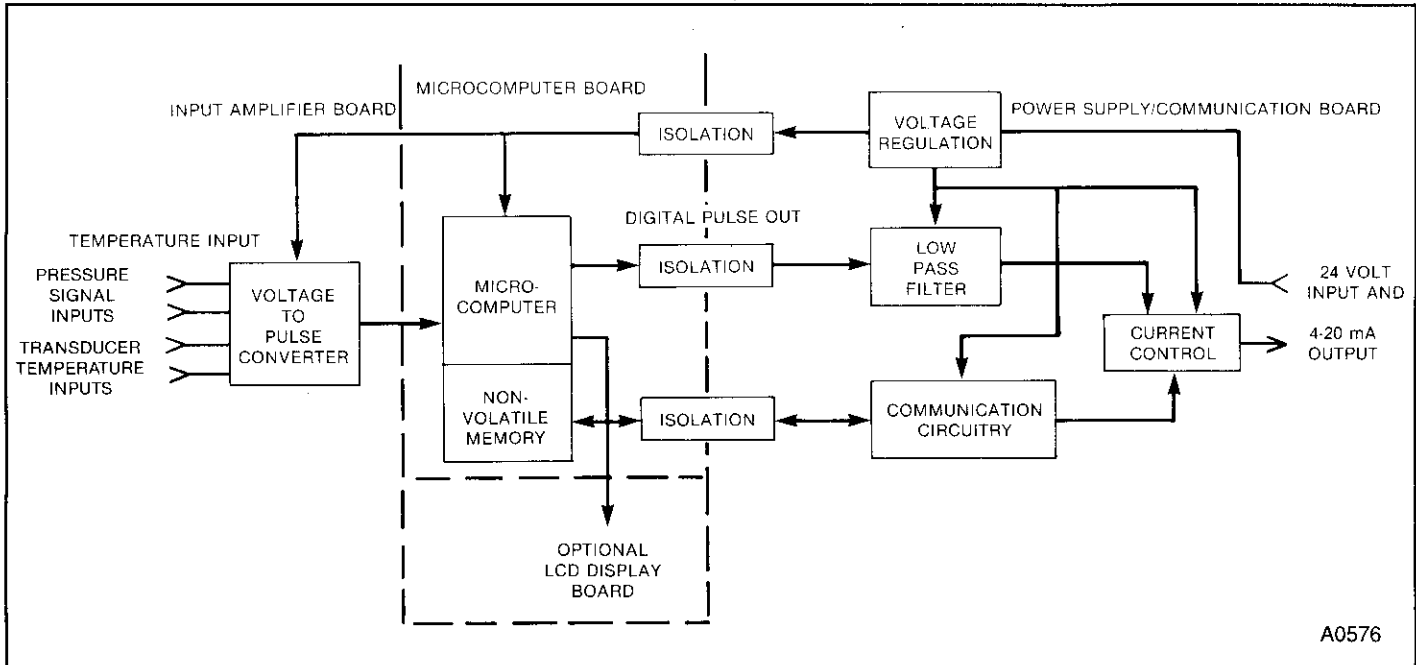

FIGURE 4 – Type BCN Smart Transmitter Electronics Block Diagram

Communication

Communication between the BCN Transmitter and a remote terminal is accomplished by attaching the STT02 anywhere along the signal wires. No adapters, jacks or plugs are necessary. An ac voltage imposed on the signal wires allow communication between the BCN Transmitter and the STT02 Terminal. Since the communication signal is high frequency ac, its dc average is zero and has no effect on the output of the transmitter. Two different frequency levels transmit a logic 0 or logic 1. This enables the location of the BCN Transmitter to be as far as one mile (1.6 Km) from the STT02 Terminal, while still maintaining excellent noise immunity for remote communication (Figure 5). A minimum of 250 ohms loop resistance is necessary to support communication capabilities (Figure 2).

The user programs the transmitter, via the STT02, to be in the digital field bus mode (Figure 6) by selecting a node address for the transmitter. When the transmitter is requested to be in the digital mode the microcomputer sets the output of the transmitter to less than 4 mA for low power consumption. When polled, the transmitter provides

a digital process variable signal. The Smart Transmitter Terminal includes an internal converter which accepts the transmitter's communication data, and alternately converts the Smart Transmitter Terminal commands to signals compatible with the transmitter.

Temperature Compensation

A temperature sensor is located within the transducer assembly. The output of the temperature sensor is monitored and used to calculate a correction for the transducer output based on programmed transducer temperature characteristics. This transmitter temperature can be monitored using the STT02 Terminal.

Diagnostics

Continuous self-diagnostics are available through the STT02 Terminal. Areas monitored are transducer, the transducer's temperature, input circuits, non-volatile memory, processor ROM, and reference voltages. The modular amplifier design allows the diagnostics to identify the malfunctioning electronic section. The diagnostics also indicate if the user is making a calibration error.

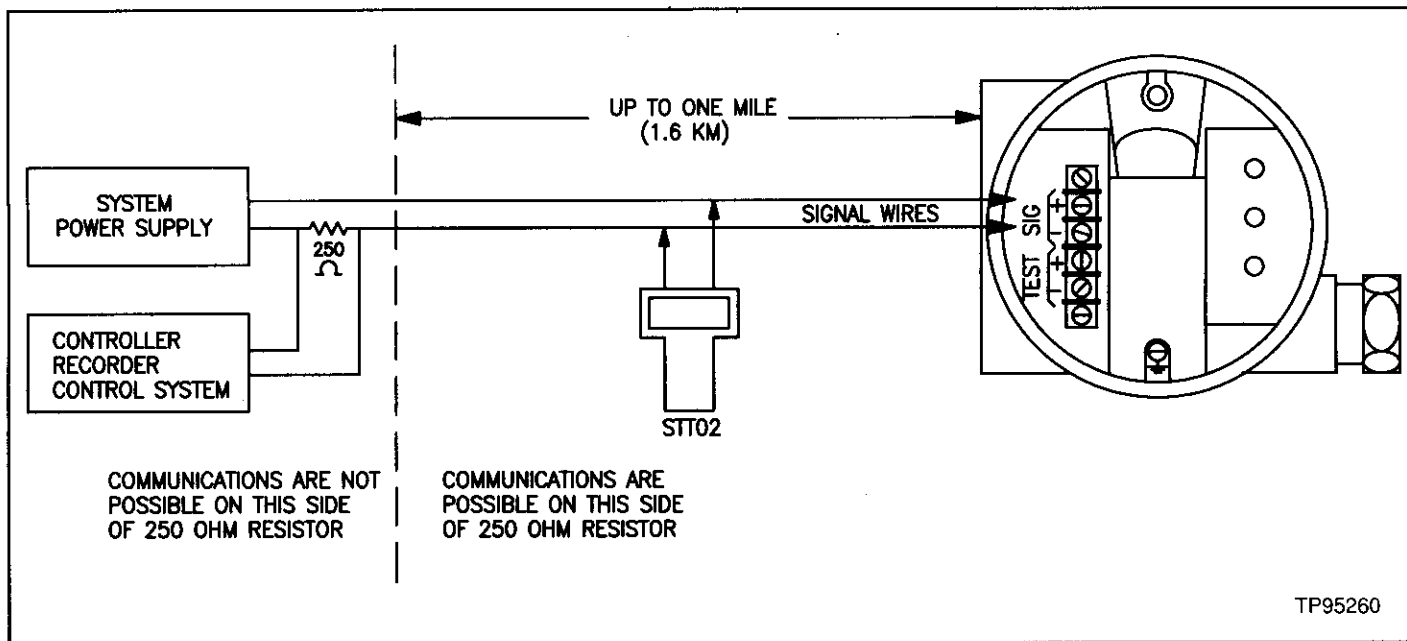

FIGURE 5 – Point-to-Point Wiring

TRANSMITTER SOFTWARE FUNCTIONS

Configuration and operational commands allow the user to input an ID Tag for the transmitter configuration, select engineering units, and define the output. The output can be defined as linear with respect to the input or several additional non-linear functions such as square root (for flow applications). The output can be set to normal or reverse acting and fixed to a specific value for

troubleshooting purposes. Other commands allow the output to be set to default values upon transmitter failure and powerup. Other commands allow the user to monitor the configuration, input, output, and status of the transmitter. A damping adjustment command is also available.

Description and Operation

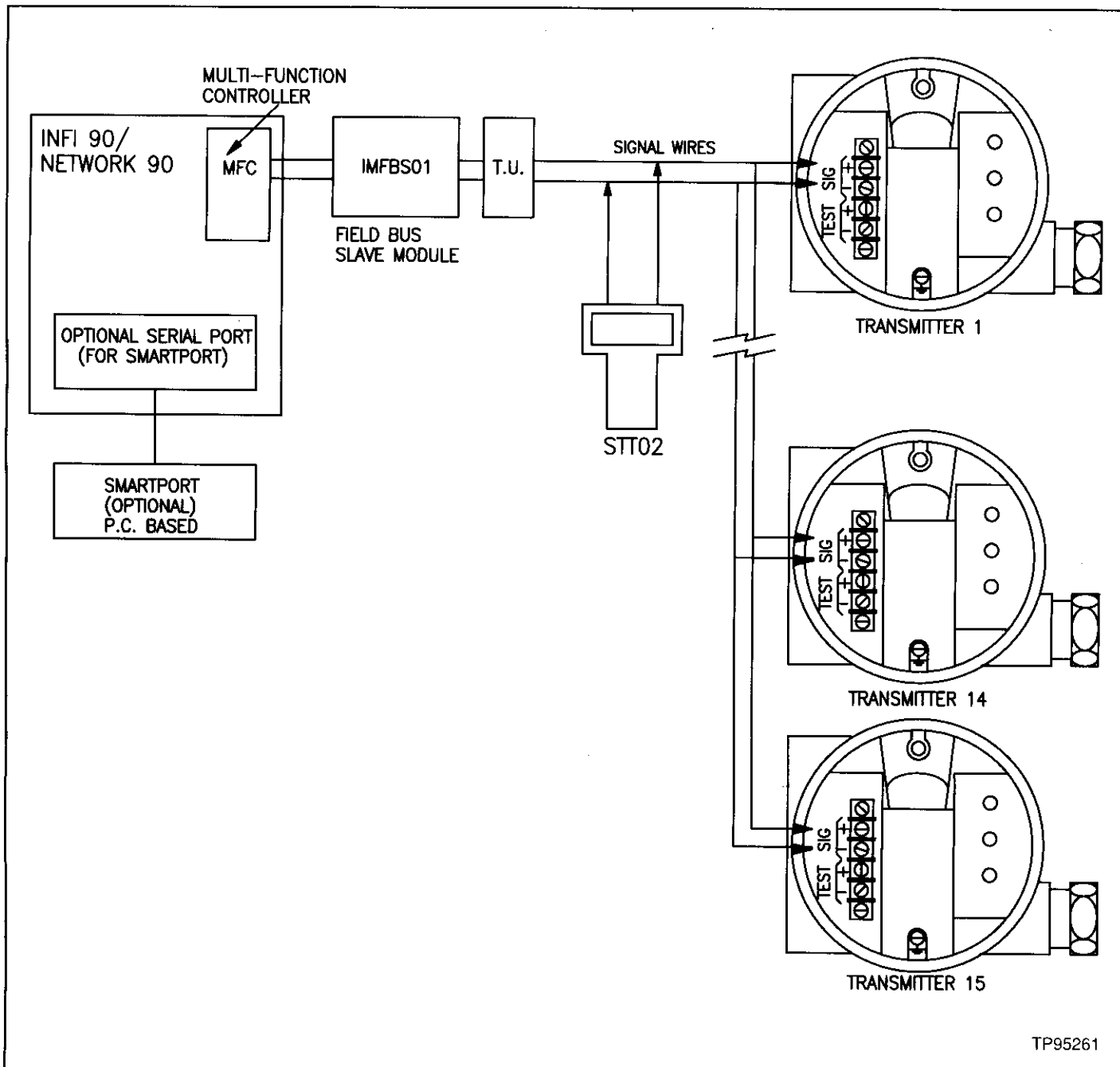

FIGURE 6 – Field Bus Arrangement

Installation

INTRODUCTION

This section provides the user with information necessary for correct installation, which is vital for safe and reliable operation of the Type BCN1 Pressure Transmitter. This information includes unpacking procedures, transmitter location considerations, and installation suggestions from piping requirements to wiring instructions.

UNPACKING AND INSPECTION

Before unpacking, carefully examine exterior of shipping containers for evidence of in-transit damage. Inspect for punctures, tears or other damage which penetrates the outer containers, and for any evidence of water damage. If damage is present, contact the carrier.

1. Examine the exterior of the transmitter for nicks, dents and scratches.
2. Before mounting or installing, check the nameplate (located on the amplifier housing) to make certain that you have received the equipment that was ordered.

WARNING

Do not, at any time, exceed the ratings listed on the nameplate.

AVERTISSEMENT

On ne doit en aucune circonstance dépasser les valeurs nominales figurant sur la plaque d'identification.

If storing the transmitter prior to installation, pack in the original container, if possible. Store in an area free of corrosive vapors and extremes in temperature and humidity. Install covers and seal all wiring inlets.

NOTE: Storage temperatures must not exceed the following limits: -58° to $+212^{\circ}\text{F}$ (-50° to $+100^{\circ}\text{C}$); Units with optional LCD Meter: -5° to $+158^{\circ}\text{F}$ (-21° to $+70^{\circ}\text{C}$).

LOCATION CONSIDERATIONS

NOTE: Refer to **APPENDIX A – APPLICATIONS IN FLAMMABLE ATMOSPHERES**, located at the back of this Product Instruction, when applicable.

The quality of a flow or level measurement depends to a great extent on proper installation of the transmitter and the pressure piping. For flow measurement, proper installation of the primary measuring element is also critical to the accuracy of the measurement. (Refer to Product Instruction I-G23-1, **Installation of Orifices and Flow Nozzles**.)

Because of process and economic considerations, it is common to install flow and level transmitters in harsh environmental locations. The location of the transmitter should, however, minimize the effects of temperature gradients and fluctuations, as well as vibration and shock.

Refer to Figure 7 for identification of the optional drain plugs. The primary purpose of the drain feature is to release residual pressure during start-up and servicing (as a bleeder valve). This applies to discharging (in gas applications). During installation, check that drain plugs, if provided, are tight before proceeding with piping installation and calibration.

SETUP AND PHYSICAL INSTALLATION

For dimensions and mounting methods, refer to Figure 7. The Type BCN1 Smart Transmitter may be supported by the piping connections if it is mounted directly at the point of measurement. It may also be surface mounted or mounted to 2-inch piping using Bailey Mounting Kit, Part No. 6634409-1 (which is included with each transmitter). Process connections on the transmitter are 1/4-18 NPT female.

After mounting, calibration should be verified to ensure that there has not been a zero shift due to mounting the unit (refer to **CALIBRATION**).

Installation

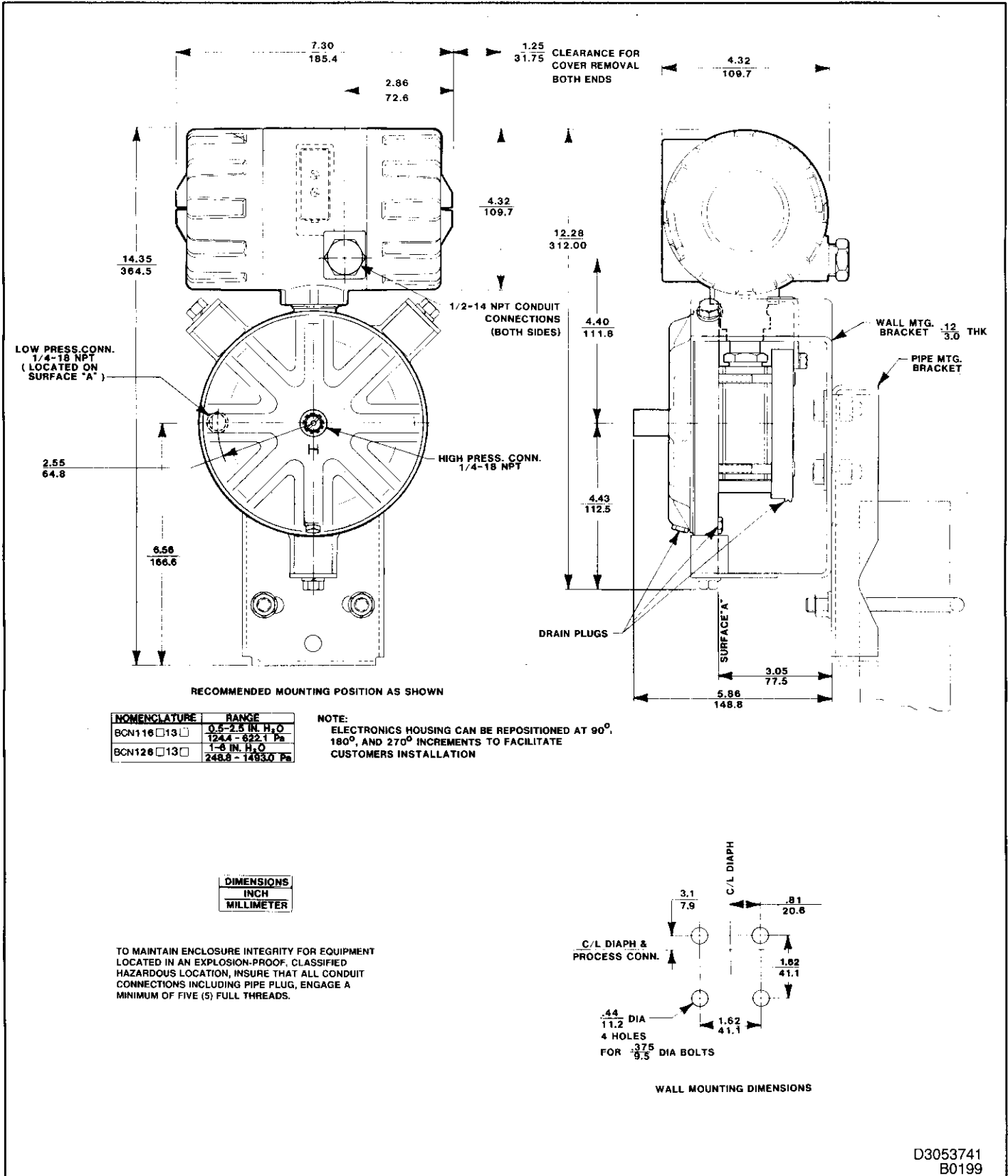

FIGURE 7 – Type BCN 1 Smart Transmitter External and Mounting Dimensions

Connecting Piping

GENERAL. Connecting piping should be in accordance with ANSI Code (B31.1.0) for Pressure Piping. The connecting piping shown in Figure 8 is a typical piping arrangement only. It is intended as a generalized guide, and may not necessarily reflect the exact configuration required for the particular service.

FLOW MEASUREMENT. Proper location of the transmitter with respect to the process pipe depends on the process material. The following should be considered in determining the best location:

1. Hot process material (above +212°F [+100°C]) must be kept out of contact with the transmitter.

2. Sediment should be kept from depositing in the pressure piping.
3. Pressure piping should be as short as possible.
4. Ambient temperature gradients and fluctuations should be minimized.

For gas flow measurement, primary element taps should be made to the top or side of flange (Figure 8). The transmitter should be mounted beside or above primary element taps to allow liquid to drain into process line.

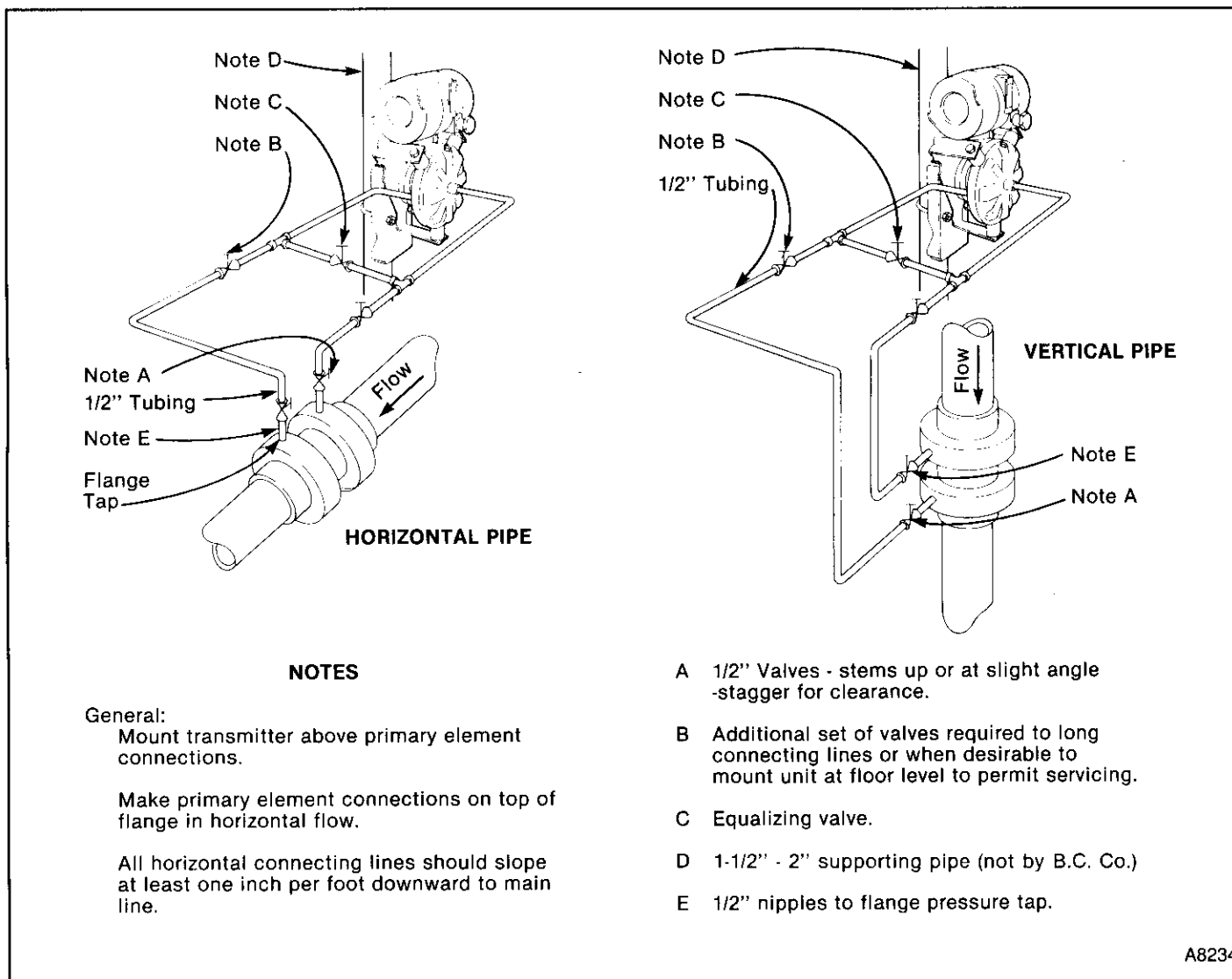

FIGURE 8 – Connecting Piping for Gas Flow Measurement

Installation

Pressure Piping

The piping between the primary element and the transmitter must transfer the pressure seen at the pipe or flange taps to the transmitter. Possible sources of error in this pressure transfer are:

1. Leaks.
2. Friction loss, when purging.
3. Temperature-induced density variations between pressure lines (head error).

The following precautions are suggested to minimize the possibility of errors:

1. Make pressure piping as short as possible.
2. Slope piping from the transmitter at least 1 inch per foot (83 mm per meter) down toward primary element for gas.
3. Keep both pressure lines at the same temperature.
4. Use pressure piping of sufficient diameter to avoid friction effects.
5. When using sealing fluid, fill both pressure lines to same level.
6. When purging, make purge connection close to primary element taps and purge through equal lengths of same size pipe. Avoid purging through the transmitter.

WIRING CONNECTIONS

Point-to-Point Mode (Analog Mode)

In the point-to-point mode of operation, the electrical connections are typical two-wire, 4 to 20 mA configuration, as shown in Figure 5. A positive (+) and a negative (-) terminal is provided at the transmitter to identify the signal leads.

NOTE: Ensure that the temperature rating of the wire is sufficient for the operating temperature.

The signal terminals located in the electronics housing will accept wire sizes up to 14 AWG. All power is supplied over the signal leads by a standard 24 V dc system power supply. Maximum supply is 42 V dc. Minimum power supply voltage is determined by the loop resistance as follows:

$$\text{Minimum Supply Voltage} = 13 \text{ Volts} + (0.02 \times \text{Load Resistance [in ohms]})$$

Load resistance must include the resistance of any meters external to the transmitter, the wiring, and the system input. Power supply regulation is not critical as long as supply voltage remains above the minimum value required to drive the external load resistance (see Figure 2).

Two "TEST" terminals located next to the signal terminals allow connection of a milliammeter so loop current can be monitored without disturbing the existing wiring.

NOTE: When jumper (31, Figure 16) is removed from terminal block, the minimum supply voltage for the transmitter increases to 13.7 V dc. This value should be used when calculating minimum supply voltage.

Field Bus Mode (Digital Mode)

In the field bus mode of operation, there is no 4 to 20 mA output signal as in the point-to-point mode. The transmitter always draws less than 4 mA to maintain operation. In this mode, up to 15 transmitters can share a common set of wires (Figure 6).

In the field bus mode, the process variable signal of each transmitter is a digitally polled variable. The Field Bus Slave Module (IMFBS01), sequentially polls each transmitter output on the bus. Each transmitter on the bus has its own unique address which is assigned during calibration (see **CALIBRATION** section). Using these addresses, the IMFBS01 knows which transmitter it is communicating with.

Each transmitter present on the bus is wired to the control system by connecting the signal leads from the control system to the positive (+) and negative (-) terminals of the transmitter. Transmitters on the bus are to be connected in parallel.

Minimum power supply voltage is determined by the loop resistance as follows:

$$\text{Minimum Supply Voltage} = 13 \text{ volts} + [(0.004 \times \text{no. of transmitters on bus}) \times (\text{load resistance})]$$

Load resistance must include the system input resistance and the resistance of the wire. Do not include meters or measuring devices in the field bus loop since the transmitters are not delivering an analog process variable. Power supply regulation is not critical assuming the supply voltage to the transmitter remains above 13 volts. This is

the minimum voltage required to properly drive the transmitter.

The STT02 can be connected anywhere there is access to the signal leads. Since the STT02 also has its own bus address, it can be connected to the bus while the control system is on line. Only one STT02 can be connected to the bus at any one time. While the field bus is on-line, the STT02 can monitor any transmitter on the bus.

In order to change any calibration or configuration parameters of transmitters using the STT02, the IMFBS01 Module must be taken off-line or the IMFBS01 Module must be instructed to bring the desired transmitter off line. This is done at the INFI 90 or NETWORK 90 console.

Signal wiring should not be run in conduit or open trays with power wiring and should not be run near heavy electrical equipment. Twisted shielded pairs are recommended for best results. The transmitter has reverse polarity protection to protect against accidental reversal of field wiring connections.

NOTE: Refer to the IMFBS01 Instruction Manual, I-E96-302 for wire length and wiring practices in the field bus mode.

GROUNDING

Signal wiring may be either ungrounded (floating) or grounded at any one point in the signal loop. When connecting more than one transmitter to a single power supply, grounding should be at the supply. The transmitter case must also be grounded. A ground terminal is found inside the electronics housing near the signal wiring terminals.

HAZARDOUS LOCATIONS (Flammable Atmospheres)

The BCN Smart Transmitter must not be located in a hazardous (classified) location unless factory marked as suitable for that location. This equipment must be installed and operated per **APPENDIX A, Applications in Flammable Atmospheres.**



Calibration

INITIAL CALIBRATION

The transmitter is completely calibrated at the factory. If a calibration check is desired before placing the transmitter in service or if calibration is required due to repair, an overpressure condition, or replacement of parts, follow the procedures outlined in **Checkout**.

Checkout (Calibration Check)

If using the point-to-point mode of operation:

1. Connect the transmitter in a calibration setup (see Figure 9). Position the transmitter in the same position as final installation.

2. With both sides vented to the atmosphere; check the output. It should be:

$$4.00 \pm 0.016 \text{ mA.}$$

3. If the output is not within the limits stated in Step 2, recalibrate the unit by pressing the CALIBRATE key on the STT02 and follow the step-by-step procedures (refer to STT02 Product Instruction).

4. Apply the full range pressure to the “H” side and check the output. It should be:

$$20.000 \pm 0.016 \text{ mA.}$$

5. If the output is not within the limits stated in Step 4, recalibrate the unit by pressing the CALIBRATE key on the STT02 and follow the step-by-step procedures (refer to STT02 Product Instruction).

If using the field bus mode of operation:

1. Connect the transmitter in a calibration setup (see Figure 9). Position the transmitter in the same position as final installation.

2. With both sides vented to the atmosphere; check the 4 to 20 mA output. It should be below 4 mA. Press the OUTPUT key on the STT02 and select *REPORT OUTPUT*. The STT02 screen should read:

$$0\% \pm 0.10\%.$$

3. If the digital output is not within the limits stated in Step 2, recalibrate the unit by pressing the CALIBRATE key on the STT02 and follow the step-by-step procedures (refer to STT02 Product Instruction).

4. Apply the full range pressure to the “H” side and check the 4 to 20 mA output. It should be below 4 mA. Press the OUTPUT key on the STT02 then select *REPORT OUTPUT*. The STT02 should read:

$$100\% \pm 0.10\%.$$

5. If the digital output is not within the limits stated in Step 4, recalibrate the unit by pressing the CALIBRATE key on the STT02 and follow the step-by-step procedures.

NOTE: If the 4 to 20 mA output does change with respect to pressure, the transmitter is not in the digital mode. Press the CONFIG key and follow the instructions to configure transmitter for the digital mode.

Temperature Compensation

A temperature sensor located within the neck of the transducer assembly reports the transducer’s temperature to the microcomputer. Using this temperature along with user-entered temperature coefficient data (Figure 10), temperature compensation is performed.

Temperature compensation data should be checked prior to bench calibration, since the temperature coefficient can affect the output. This temperature coefficient data is found on a label mounted in the electronics side of the amplifier housing. The data on this label contains temperature compensation data for Smart BCN and Smart BC sensors (Figure 10). Temperature compensation is as follows:

1. Using the STT02, press the CALIBRATE key, select *BENCH CALIB.* and follow the step-by-step instructions. The STT02 will ask for the ambient temperature of the transducer in degrees Celcius. It is important for operation that this temperature be within $\pm 1^\circ\text{C}$ to the actual temperature. This information is used to calibrate the temperature sensor. By performing this calibration, the transmitter knows which sensor type it is addressing. (Conventional BC, Smart BC or Smart BCN).

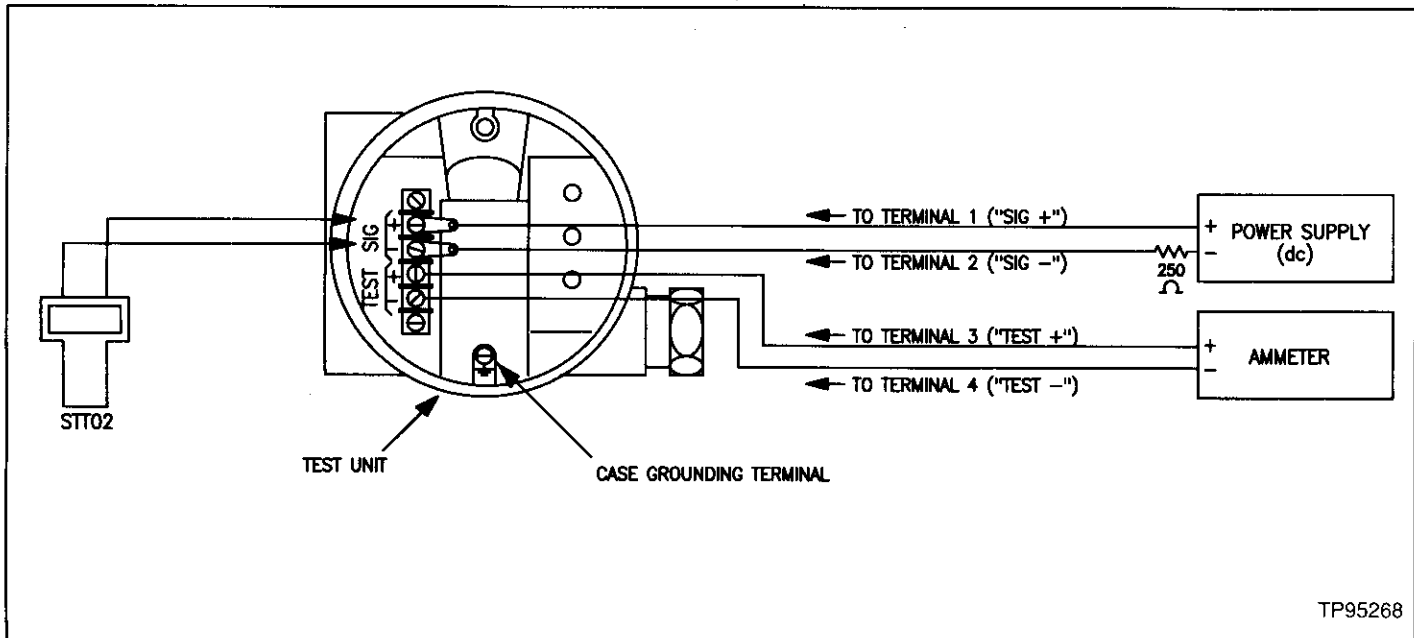

FIGURE 9 – Typical Calibration Setup

2. When the sensor type is established, the STT02 will ask if the temperature coefficient data will be viewed. Select *YES* and press enter. The STT02 will display the appropriate screen for entering temperature compensation data. If the value is correct, press *ENTER*, otherwise input the correct values.

3. The checksum number that appears with the other temperature coefficient data is provided for error detection. The checksum ensures that the coefficient data is inputted correctly. If any of the data is incorrectly entered, the STT02 will ask that the numbers be re-entered.

Smart BCN sensor: the STT02 asks for temperature coefficient data (zero and span shift, A through E). Enter the data found on the label inside the housing as prompted by the STT02. (See Figure 10.)

Smart BC sensor: the STT02 will ask for temperature coefficient data (zero and span shift) in percentage form

according to transducer temperature. Enter appropriate data from the label located inside the amplifier housing.

Conventional BC sensor: the STT02 will display the screen for the BCN sensor. The user should enter zeros for all values including checksum. The conventional BC sensor provides its own temperature compensation.

Changing Calibration (Linear/4 to 20 mA Output)

1. All calibration is done electronically by the STT02 Smart Transmitter Terminal. Connect transmitter in a calibration setup (see Figure 9). Position the transmitter in the same position as the final installation.

2. Readjust the transmitter by pressing the *CALIBRATE* key on the STT02, select *BENCH CAL* and follow the directions given by the STT02.

NOTE: The data appearing in Figure 10 is sample data, used for illustrative purposes. The data for actual use is located inside the amplifier housing.

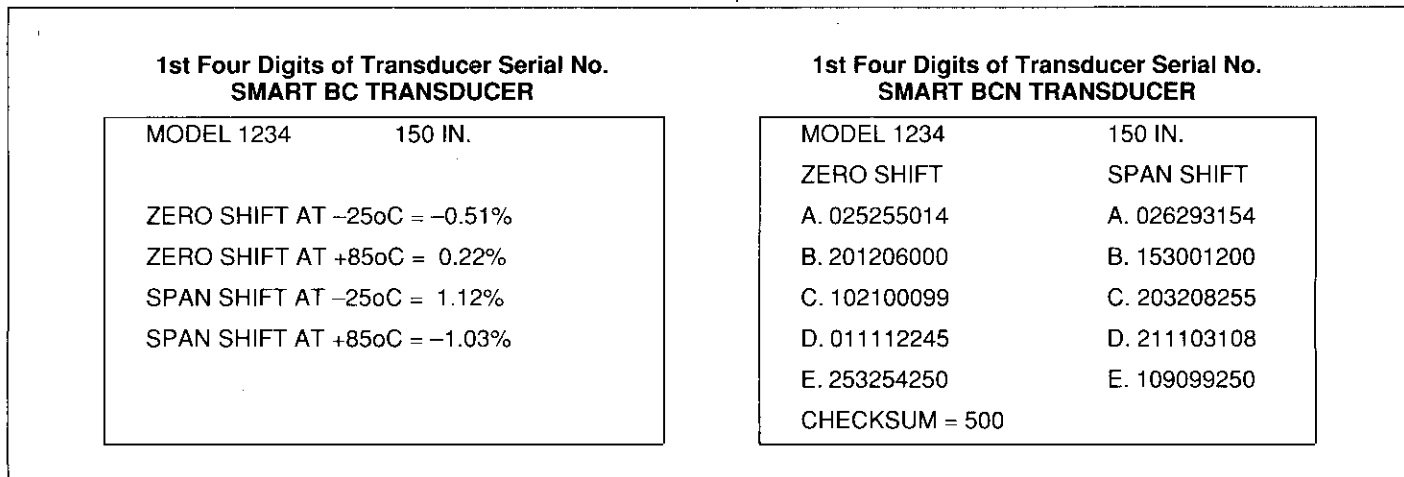

FIGURE 10 – Sample Temperature Compensation Data Label

Operating Procedures

INTRODUCTION

This section provides the user with the configuration parameters necessary to set the transmitter for your application. Also discussed are start-up and failure conditions for the BCN Pressure Transmitter.

Transmitter configuration requires the STT02.

OPERATOR INTERFACE

The Bailey Type BCN Smart Transmitter can be monitored and controlled using the Bailey Type STT02 Smart Transmitter Terminal. It can be connected anywhere there is access to the signal wires. Connect the STT02 across the signal wires in a parallel connection.

Refer to the STT02 Smart Transmitter Terminal Product Instruction, I-E21-28, for STT02 operating procedures.

Configuration Procedure

The Bailey Smart Transmitter is configured using the STT02 Smart Transmitter Terminal. Configuration of the transmitter includes defining an identification tag, digital or analog mode of operation, primary engineering units, secondary units and secondary lower and upper range values, output parameters, damping constant, primary lower and upper range values.

Press the CONFIGURE key and follow the step-by-step procedure. After saving a configuration in the terminal's memory, it can be sent to a connected transmitter using the SEND CONFIG key. (Refer to STT02 Product Instruction.) The following paragraphs explain the configuration parameters.

TRANSMITTER ADDRESS. The transmitter address is used for field bus transmitters. Each transmitter on the field bus must have a separate address. The address range is 1 through 15. If the transmitter address is programmed to be between 1 and 15, the transmitter will put itself into the field bus mode (digital mode). The output will be locked below 4 mA. If the user specifies analog mode (point-to-point) instead of selecting a particular address,

the transmitter will then be in the analog mode thus providing a 4 to 20 mA output signal.

Under no circumstance should a transmitter configured for point-to-point mode be connected to a field bus. The field bus will not support analog output devices.

ID TAG. The Smart Transmitter ID tag is a 12-character alphanumeric tag which can be programmed into the transmitter. It is different than the previously discussed Transmitter Address. The ID tag is inputted by the user during configuration for the user's own identification needs. To display the ID tag on the screen, press the STATUS key on the STT02; the user specified ID tag will appear.

OUTPUT TYPE. The output of the transmitter must be specified as linear with respect to the input, as the square root of the input, or as a function generator that follows a six segment linear function programmed by the user. If a function generator output is chosen, five input and output points must be specified as a percent of input. Note that the first and last point on the curve are assumed to be 0.00 and 100.0%. The user should program five points between these two values.

OUTPUT ACTION. A transmitter in the normal acting mode has an output that increases with increasing input. The output of a transmitter in the reverse acting mode decreases with increasing input.

DAMPING ADJUSTMENT. Damping is adjustable and provides time constant values from 0.00 to 32.00 seconds. Damping adjustments have no effect on the calibration or accuracy of the transmitter, however it can be used to "smooth out" a fluctuating input signal.

PRIMARY ENGINEERING UNITS. Smart transmitter primary engineering pressure units can be defined. Note that when the engineering pressure units are changed, (i.e. psi to inches H₂O) the upper and lower range values will automatically be recalibrated to match the new units. The limits are ±9999. (See example.)

Operating Procedures

Example: primary engineering units changed from psi to H₂O.

Engineering units are psi.

Lower range value: 0 psi

Upper range value: 1 psi

Engineering units changed to inches H₂O.

Lower range value automatically becomes:
0 inches H₂O.

Upper range value automatically becomes:
27.7 inches H₂O.

PRIMARY LOWER & UPPER RANGE VALUES.

The transmitter's range may be set electronically to any value within $\pm 100\%$ of the upper range limit to suit a specific application need.

SECONDARY (FLOW) ENGINEERING UNITS.

Secondary (flow) engineering units can be programmed. These units are in a free form format of six characters. Any six characters can be programmed into the transmitter, such as mA or GAL/HR. These units are used in conjunction with the secondary lower and upper range values. Use the up-down arrow keys or decimal number keys to select the secondary units.

SECONDARY (FLOW) LOWER AND UPPER RANGE VALUES. The transmitters secondary lower and upper range value can be set to any range within ± 9999 . These ranges can be monitored by the STT02 or displayed on the optional LCD display. These ranges are a function of the output of the device. If selecting a non-linear output such as square root, the output to the STT02 will be in units representing the non-linear square root function. The flow output can be polled from the device or displayed on the LCD screen. These ranges have no effect on the calibration of the transmitter and are used so that the user can report the output of the transmitter in units that are familiar.

LOCAL LCD SET UP. The local LCD can be programmed to display output in percent, input in pressure engineering units or output in secondary engineering units. This feature can be programmed using the SPECIAL FEATURE key on the STT02.

Start-up and Failure Conditions

WARNING

The output of this equipment changes to a fixed value during start-up and transmitter detected failure conditions. These values must be selected by the user to ensure safe operation.

AVERTISSEMENT

La sortie de cet appareil adopte une valeur fixe lors de la mise sous tension et de certaines conditions de pannes. Ces valeurs fixes doivent être sélectionnées par l'utilisateur pour assurer une sécurité d'opération lorsqu'elles surviennent.

On power-up, there is a two second initialization period during which the output of the transmitter is either above 100% or below 0%, (approximately 3.8 mA) as defined by the user during configuration. *INITIALIZE LOW* sets the output to below 0% while *INITIALIZE HIGH* sets the output to above 100% (approximately 21 mA). The default initialization value is low (below 0%). After initialization, the output ramps up or down to the correct value.

If, during its continual diagnostics, the microcomputer detects a problem that is fatal to the transmitter or system, the transmitter output will be set to a predetermined level. This level must be selected by the user during configuration. The default value is set low (below 0%). Table 1 in the **TROUBLESHOOTING** section, shows what types of errors will cause the transmitter to go into the fail mode.

NOTE: For a transmitter in the normal acting mode, 0% output would be 4 mA and 100% output would be 20 mA. For a transmitter in the reverse acting mode, 0% output would be 20 mA and 100% output would be 4 mA.

Get Configuration Procedure

Once a Smart Transmitter has been configured, the configuration may be viewed by pressing the GET CONFIG key on the STT02 (refer to STT02 Product Instruction).

Monitor Input Procedure

The input to the Smart Transmitter can be monitored by pressing the **OUTPUT** key on the STT02 and selecting **REPORT INPUT** from the display menu (refer to STT02 Product Instruction). The input is displayed in primary engineering units and the display is updated every second.

Monitor Output Procedure

The Smart Transmitter output can be monitored by selecting the **OUTPUT** key on the STT02, and choosing **REPORT OUTPUT** from the display menu (refer to STT02 Product Instruction). The output will be displayed as a percent, rather than in mA, and the display will be updated every second.

Monitor Secondary Engineering Units Procedure

The secondary engineering units variable can be monitored by the STT02 by pressing the **OUTPUT** key and selecting **SECONDARY UNITS**. The output will reflect the output of the transmitter but it will be a percentage of the secondary lower and upper range value. This value will be displayed in secondary engineering units.

Example: If secondary lower range value is 0.0 GAL/HR and the secondary upper range value is 100 GAL/HR and the output of the transmitter is at 50%, the display will read 50% range or 50 GAL/HR.

Monitor Transducer Temperature Procedure

By pressing the **OUTPUT** key and selecting **MONITOR TEMPERATURE**, the STT02 can display the ambient temperature of the transducer. The temperature is displayed in degrees Celcius.

NOTE: When a conventional transducer has been upgraded to Smart BCN electronics, the transmitter will always display 25°C (77°F) for the transducer temperature. This transducer does not have a temperature sensor that the BCN electronics can access.

Fix Output Procedure

For system troubleshooting purposes, the Smart Transmitter output can be set to a constant, specified as percent of span input. Press the **SPECIAL FEATURE** key and select **FIX OUTPUT** to set the constant (refer to STT02 Product Instruction). To cancel **FIX OUTPUT**, press the

SPECIAL FEATURE key and select **CANCEL FIX OUTPUT**.

Transmitter Status Check Procedure

The status of the transmitter, determined from results of the continuous self-diagnostics, can be checked using the **STATUS** key on the STT02. Refer to the **TROUBLESHOOTING** section for corrective action as needed.

Special Operating Considerations

CONFIGURATION LOCKOUT PROCEDURE. The Smart Transmitter has a “lockout” feature that, once engaged, allows all transmitter functions to be monitored but prevents the transmitter configuration from being altered.

To use the “lockout” feature, change the staple jumper J1 on the microcomputer board of the transmitter from pins 2 and 3 to pins 1 and 2. Refer to Figure 11 for jumper J1 location and positions. To gain access to the upper amplifier board, refer to **Replacing the Amplifier Housing Components** in the **REPAIR/REPLACEMENT** section of this Product Instruction.

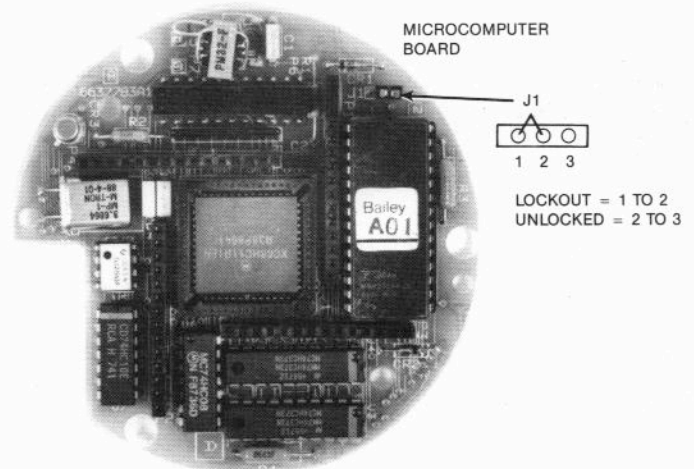

A0754

FIGURE 11 – Lockout Jumper J1 Location and Position on Microcomputer Board.



Troubleshooting

INTRODUCTION

If the Type BCN Transmitter is unable to implement any command, the STT02 Terminal will be prompted. Pressing the STATUS key on the STT02 will enable the user to see what problem exists. When a problem is encountered, Table 1 assists the user with troubleshooting by listing error messages (as displayed on the STT02), probable causes and corrective action associated with the error. Table 2 lists

possible output problems, and corrective action. Figure 12 is a troubleshooting flow chart for the amplifier assembly.

NOTE: More than one error can be present on one transmitter, however, only one error at a time can be displayed on the STT02. Therefore, error messages on the STT02 are based on a priority structure. The error holding the most significance to the system will be displayed first and any that follow will appear according to their rank on the priority structure.

ERROR MESSAGES AND CORRECTIVE ACTION

TABLE 1 – Error Messages

ERROR	PROBABLE CAUSE	CORRECTIVE ACTION
TRANSMITTER CHECKSUM ERROR	The data the transmitter received did not pass a checksum test (data corrupted).	Extreme line noise can cause this message to randomly appear. Since transmitter and STT02 do check data for integrity, this is not a problem. If this error message appears frequently, replace communication board. Refer to Replacing Amplifier Housing Components for board replacement.
TRANSMITTER CAN'T EXECUTE COMMAND: HARDWARE PROBLEM	Detect error in hardware.	Press STATUS key to determine error and use this table for the appropriate corrective action.
TRANSMITTER CAN'T EXECUTE COMMAND: LOCKOUT ENGAGED	The hardware lockout jumper on the microcomputer board is set in the lockout mode. (The user cannot change any parameters when this jumper is set in the lockout mode.)	Refer to Configuration Lockout Procedure to change jumper position on the microcomputer board.
TRANSMITTER CAN'T EXECUTE COMMAND: FBS ON LINE	The STT02 cannot change any transmitter parameters while the field bus is active.	Transmitter must be brought off-line. Slave can bring transmitter off-line, or the slave can be unplugged from the rack. There is two-minute time out period until the STT02 will be allowed to change parameters. After the two-minute period, the transmitter will allow the STT02 access.
*TRANSMITTER EPROM CHECKSUM ERROR	Program chip on microcomputer board is bad	Replace microcomputer board. Refer to Replacing Amplifier Housing Components for replacement procedures.
*TRANSMITTER FAILED RAM CHECK	RAM is inoperable because micro-computer chip is defective	Replace microcomputer board. Refer to Replacing Amplifier Housing Components for replacement procedures.
*TRANSMITTER EEPROM FAILURE	Microcomputer has detected a memory problem.	Reconfigure the transmitter and recalibrate it. The microcomputer will attempt to correct the problem. If it cannot after three attempts it will send out a MICRO-COMPUTER BAD error message. Refer to that code in this table.
*TRANSMITTER μ P HAS BAD EEPROM	The microcomputer cannot retain configuration and calibration data. Microcomputer board is defective.	Replace microcomputer board. Refer to Replacing Amplifier Housing Components for replacement procedures.
*TRANSMITTER INTERNAL REFERENCE FAILURE	Input board defective. Most probable cause.	Replace input board. Refer to Replacing Amplifier Housing Components for replacement procedures.
	Microcomputer board defective. Least probable cause.	Replace microcomputer board. Refer to Replacing the Amplifier Components for replacement procedures.

Troubleshooting

TABLE 1 – Error Messages (continued)

ERROR	PROBABLE CAUSE	CORRECTIVE ACTION
*TRANSMITTER MAIN INPUT FAILURE	Sensor failure. Most probable cause.	Check input board connections. Refer to Replacing Amplifier Housing Components for replacement procedures to allow a check of connections. Check jumper selections on the input board.
	Input board failure. Least probable cause.	Replace input board. Refer to Replacing Amplifier Housing Components for replacement procedures.
*TRANSMITTER INPUT OVER RANGE or UNDER RANGE	Pressure out of range.	a. Make certain proper input is applied to transmitter. Recalibrate. If error still present, input board defective. Go to step b.
	Jumper connections not correct.	b. Check jumper connections. Remove the amplifier assembly. Refer to Replacing Amplifier Housing Components for replacement procedures.
	Input board not connected properly.	c. Check connections. d. Replace input board. Refer to Replacing Amplifier Housing Components for replacement procedures.
TRANSMITTER INPUT APPLIED INCORRECTLY	Input signal is not at specified level.	Correct signal and recalibrate. Refer to CALIBRATION section.
TRANSMITTER OUTPUT IS FIXED OR IN ADJ. MODE	STT02 turned off when output was fixed to a value or while the 4 to 20 mA output was being adjusted.	Power down the transmitter then power up the transmitter.
TRANSMITTER TEMPERATURE OVER 85°C or UNDER -25°C	Transmitter not calibrated properly, or transmitter is at a temperature limit at which the temperature performance is not specified. Error message will not affect operation but could mean that temperature performance is out of spec.	Recalibrate the transmitter. Refer to the CALIBRATION section. NOTE: Uncalibrated transmitters may have this error message until calibrated.
TRANSMITTER NOT RESPONDING	a. STT02 is not connected to transmitter.	a. Connect STT02 across transmitter terminals. Use cord with clip connectors.
	b. Transmitter does not have a minimum of 13 V dc across inputs.	b. Correct power problem.
	c. Not using correct communication method.	c. Turn off STT02, turn on and select FSK/BUS and press ENTER. ID Tags will appear on screen. Select the ID Tag of the transmitter or select the one appearing within brackets if unsure of ID Tag. Press ENTER. Press STATUS key. If this error message still present, refer to step d.
	d. Transmitter or STT02 is defective.	d. If available, verify that the STT02 is functional by connecting it to another transmitter. If STT02 is not functional, replace. If STT02 is functional; replace communication board on transmitter (refer to Replacing Amplifier Housing Components .)
		If problem still is present; replace microcomputer board in transmitter (refer to Replacing Amplifier Housing Components .)
e. Transmitter does not have a minimum of 250 ohms in communication loop.	Install a minimum of 250 ohms in the loop.	

* Transmitters with this error will enter into the Fail Mode that was specified in transmitter configuration.

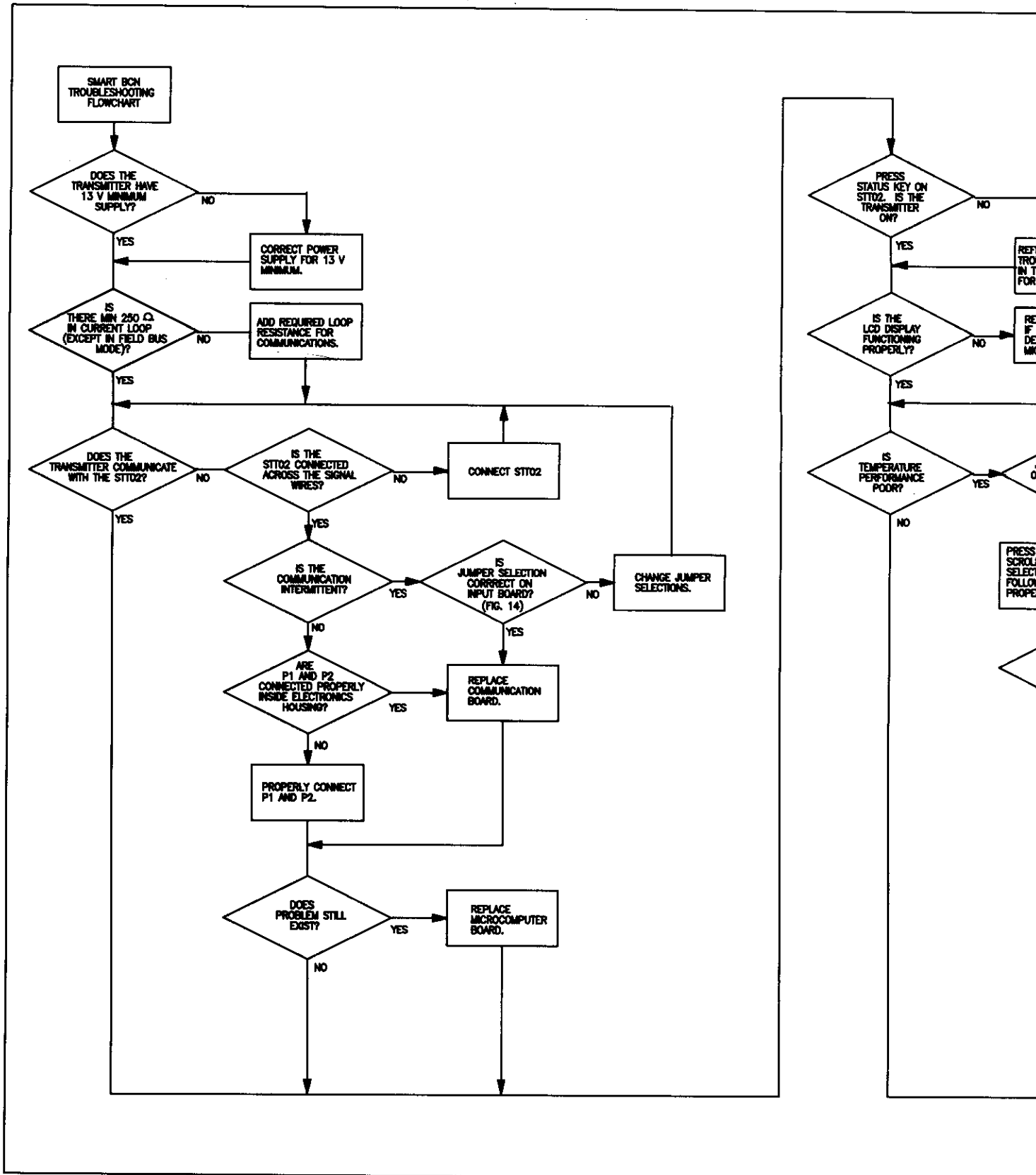

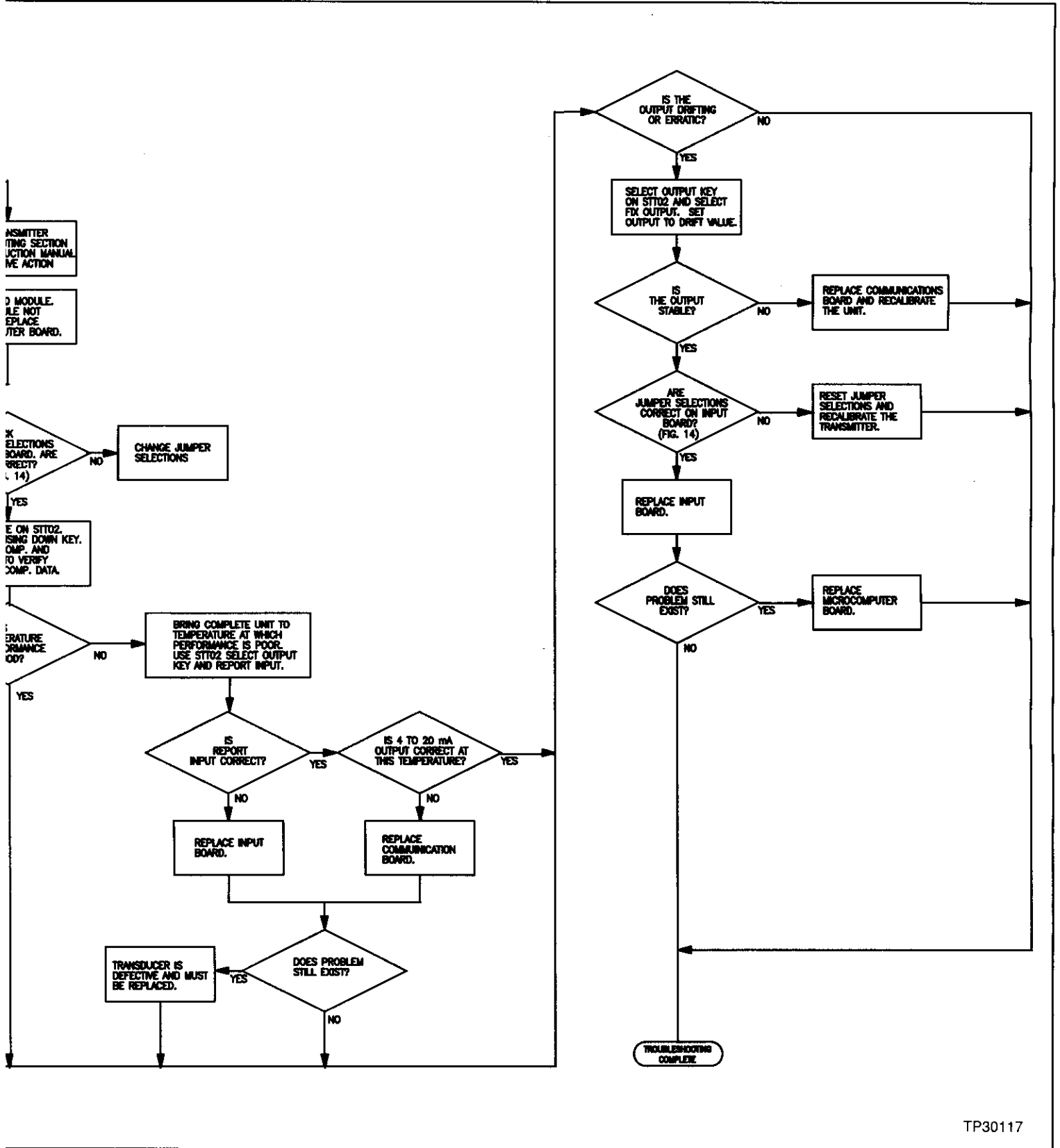

TP30117

FIGURE 12 – Troubleshooting Flow Chart

Troubleshooting

TABLE 2 – Troubleshooting Chart

SYMPTOM	PROBABLE CAUSE	CORRECTIVE ACTION
HIGH OUTPUT	Primary element	Check for restriction at the primary element.
	Pressure piping	Check for leaks or blockage. Check that blocking valves are fully open. Check for entrapped gas in liquid lines and for liquid in dry lines. Check that density of fluid in pressure lines is unchanged. Check for sediment in transmitter process flanges.
	Transmitter electronics connections	Make sure pins and receptacles are clean and check sensor connections.
	Transmitter electronics failure	Refer to Figure 12 – Troubleshooting Flow Chart.
	Transducer	Refer to Transducer Check .
ERRATIC OUTPUT	Loop wiring	Check for intermittent shorts, open circuits, and multiple grounds.
	Process fluid pulsation	Install dampers in pressure piping.
	Pressure piping	Check for entrapped gas in liquid lines and for liquid in dry lines.
	Transmitter electronics connections	Check for intermittent shorts and open circuits. Make sure pins and receptacles are clean and check sensor connections.
	Transmitter electronics failure	Refer to Figure 12 – Troubleshooting Flow Chart.
LOW OUTPUT OR ZERO OUTPUT	Power supply	Check output of power supply.
	Loop wiring	Check for shorts and multiple grounds.
	Check loop impedance.	Check polarity of connections.
	Primary element	Check installation and condition of element. Note any changes in process properties which may affect output.
	Pressure piping	Check that high and low pressure connections are correct. Check for leaks or blockage. Check that blocking valves are fully open and that bypass valves are tightly closed. Check for entrapped gas in liquid lines and for liquid in dry lines. Check that density of fluid in pressure piping is unchanged. Check for sediment in transmitter process flanges.
	Device in digital mode	If analog output is desired, reconfigure using the CONFIG key for analog mode. Use the SEND CONFIG key to send the configuration to the transmitter.
	Transmitter electronics connections	Check for shorts in sensor leads. Make sure pins and receptacles are clean and check sensor connections.
	Test diode failure	Replace test diode or jumper test terminals.
	Transmitter electronics failure	Refer to Figure 12 – Troubleshooting Flow Chart.
Transducer	Refer to Transducer Check .	

Maintenance

INTRODUCTION

This section provides the user with maintenance procedures that are necessary in order to ensure reliable service from the BCN Transmitter.

WARNING

System maintenance must be performed only by qualified personnel and only after securing equipment controlled by the circuit. Altering or removing components from an active circuit may upset the process being controlled.

AVERTISSEMENT

L'entretien du système doit être effectué par des personnes compétentes et uniquement à partir du moment où les éléments contrôlés par le circuit ont été isolés. Le fait d'enlever ou d'altérer les composants d'un circuit sous tension peut perturber le processus contrôlé.

MAINTENANCE SCHEDULE

Amplifier Housing

Maintenance as it pertains to the BCN Transmitter, is limited by the nature of its function. It has no moving parts that need tending, rather it contains solid state electronic components which, when operated within specifications, needs no maintenance. The amplifier housing is rated NEMA 4X, providing excellent isolation of the electronics from harmful atmospheric conditions.

NOTE: If transmitter malfunctions, some troubleshooting procedures involve the electronics portion of the transmitter (see **TROUBLESHOOTING**).

Transducer Assembly

The transducer portion of the BCN Transmitter does require some maintenance. The maintenance is application dependent.

FLANGE. It is important to keep the flange free of deposits. This normally is not a problem; however, when the transmitter is used in a area where dust and process overspray is heavy, it is necessary to keep flange free of excessive accumulation of process residue.

NOTE: When cleaning the exterior of the transmitter, it is common to hose the unit down to free it of dust and process deposits. When this is done, the temperature of the medium (water, steam, or air) should not exceed specifications of the transmitter (see **Performance/Functional Specifications** for temperature limits).

TRANSMITTER REZERO. This maintenance procedure is necessary only when the highest degree of accuracy is needed. In most applications, rezeroing the transmitter is not necessary unless transducer or amplifier assemblies have been replaced. Press the **CALIBRATE** key and select **REZERO** and follow the procedure displayed on the STT02.



Repair/Replacement

INTRODUCTION

Repair/Replacement section gives the user methods for checking the status of BCN components; including the transducer and the amplifier assembly. This section also outlines procedures for replacing components when found to be defective.

PROCEDURES

General

NOTE: Refer to **APPENDIX A – APPLICATIONS IN FLAMMABLE ATMOSPHERES** when applicable.

Bailey does not recommend the repair of printed circuit boards in the field. Equipment requiring repair should be returned to the factory or your nearest Bailey Service Center.

If the transmitter is inoperative, or if operation is faulty, refer to Table 1 and 2 for troubleshooting procedures, and the Troubleshooting Flow Chart, Figure 12.

NOTE: Before disconnecting the pressure lines, open the appropriate drain plugs to release residual pressure. When not releasing residual pressure, check that the vent/drain plugs are securely tightened.

Transducer Check

Tools Required: digital voltmeter.

SMART BCN TRANSMITTER.

1. Disconnect sensor leads from amplifier board.
2. Connect a 6.2 V dc power supply to the blue (–) and orange (+) sensor leads.
3. Connect a voltmeter to the green (+) and black (–) sensor leads.
4. Apply appropriate pressure to input and verify that the output changes with changing input pressure. (Output will be in millivolts.)
5. Connect the voltmeter to the blue (+) and brown (–) leads. For a Smart BCN sensor the voltmeter should read about 22 mV \pm 3 mV at room temperature (80oF [26.7oC]).

CONVENTIONAL AND SMART BC UPGRADED TRANSMITTER. The transducer is not field repairable and must be replaced if defective. If there is no obvious defect, the transducer may be checked as follows:

1. Disconnect sensor leads from amplifier board.
2. For a Smart BC sensor: connect the voltmeter to the yellow (+) and brown (–) leads.
3. For a Smart BC sensor: connect the supply to the blue (–) and orange (+) sensor leads.
4. Connect a voltmeter to the green (+) and black (–) sensor leads.
5. Apply appropriate pressure to input and verify that the output changes with changing input pressure. (Output will be in millivolts.)

NOTE: If checking a Conventional BC sensor, skip Step 6.

6. For a Smart BC sensor, connect the voltmeter to the yellow (+) and brown (–) leads. The voltmeter should read about 15 mV \pm 2 mV at room temperature, 80°F (26.6°C).
7. If output does not change with pressure, replace transducer assembly. After installation of the new transducer assembly, the temperature coefficients supplied with the replacement transducer must be programmed into the mating electronics to assure proper temperature compensation. The transmitter must then be calibrated. (Refer to the **CALIBRATION** Section of this Product Instruction.)

Amplifier Assembly Boards

The amplifier assembly can easily be checked for a malfunction by substituting spare circuit boards in the circuit. Refer to **Replacing the Amplifier Housing Components** for removal procedures.

AMPLIFIER BOARDS CHECK.

1. Remove LCD board, if used.

Repair/Replacement

2. Apply appropriate pressure to the input and verify that the output changes with changing input pressure. If correct operation cannot be obtained, replace with spare amplifier boards, recalibrate and repeat check. If operation still cannot be obtained, replace the transducer.

NOTE: If the amplifier boards are replaced, the temperature coefficients supplied with the transducer must be programmed into the mating electronics to assure proper temperature compensation (refer to **CALIBRATION**).

LCD BOARDS CHECK. The optional LCD board should be checked (if used) only after the amplifier boards have been verified operational.

1. Attach the LCD board to the amplifier assembly (see **Replacing the Amplifier Housing Components**).

2. Check for correct operation in this mode. If correct operation cannot be obtained, replace with spare LCD board and repeat check. If correct operation of the LCD still cannot be obtained, replace the microcomputer board.

Replacing The Amplifier Housing Components (LCD Board and Amplifier Boards Assembly)

NOTE: See Figure 13 for an exploded view of the amplifier housing assembly.

Tools required: phillips screwdriver.

1. Turn off power to the transmitter.
2. Unscrew and remove the left amplifier housing cover.
3. Remove the three screws that secure the amplifier assembly to the housing. Partially remove the assembly from the housing.

CAUTION

Do not remove or force amplifier assembly completely out of housing. This will cause damage to pin connectors at P1, P2 and the sensor lead connector.

ATTENTION

Nes pas retirer complètement l'assemblage des composants de son boîtier. Ceci endommagerait les broches et les connexion P1 et P2 ainsi que le connecteur des fils de la sonde.

NOTE: Do not try to completely remove the amplifier assembly from the housing before the sensor lead connector and pin connectors P1 and P2 have been disconnected; otherwise the pins and connectors may be damaged.

4. Disconnect the sensor lead pin connector and pin connectors P1 and P2.
5. Remove the amplifier assembly from the housing.
6. If the LCD meter is provided, remove the two screws holding the LCD shield to the amplifier assembly.
7. Disconnect the LCD connector from the microcomputer board.

NOTE: If necessary to disassemble the transducer assembly, refer to **Replacing the Transducer Assembly** at this point. If not, continue with the reassembly procedure.

8. If the amplifier boards assembly is replaced, be sure that jumpers J1, J2, and J3 on input board assembly, Bailey Part No. 6637778-1, are positioned as shown in Figure 14.

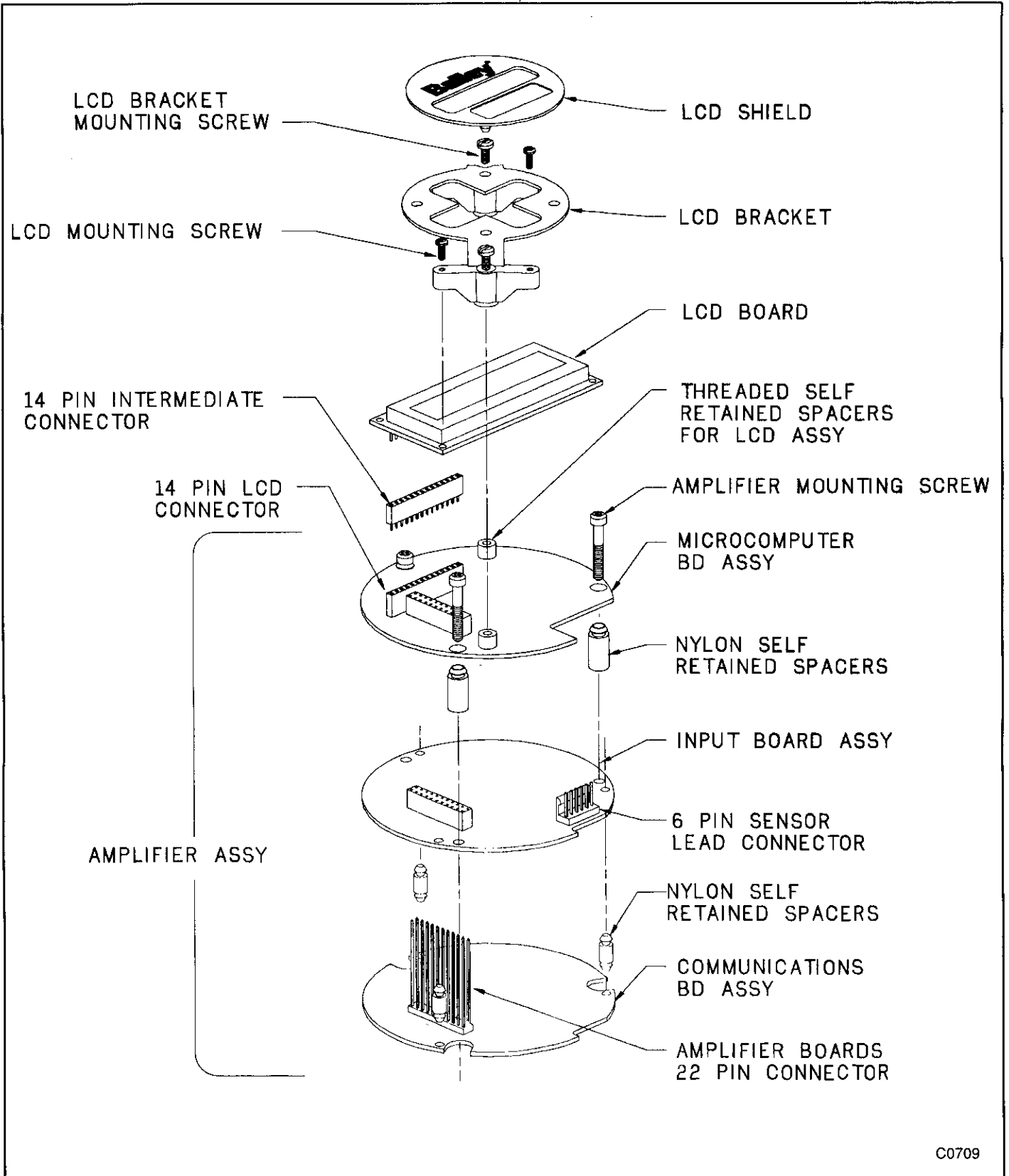

C0709

FIGURE 13 – Amplifier Assembly (Exploded View)

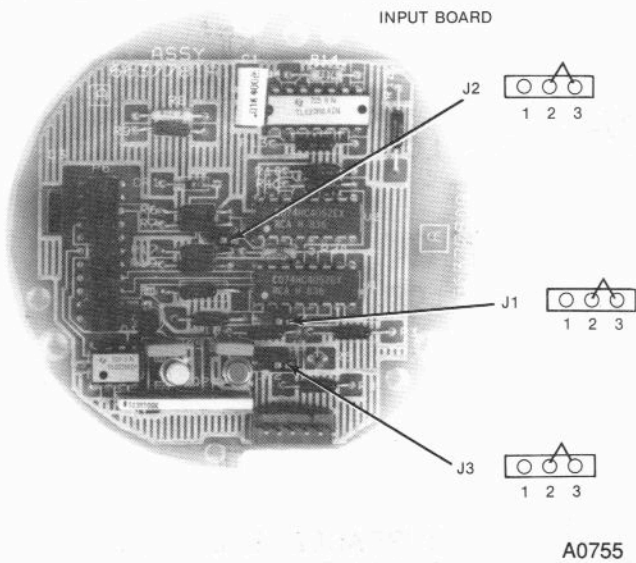

FIGURE 14 – Jumper Wire Locations and Positions on Input Board.

9. Plug LCD into amplifier assembly.

10. Using the two screws and lockwashers provided, attach the LCD bracket to the amplifier assembly.

NOTE: At this point in the assembly, make sure that all of the screws are tightened securely.

11. Partially slide the amplifier assembly into the housing. Attach the sensor lead connector and the red (P1) and black (P2) filter leads.

12. Slide the assembly completely into the housing; secure the assembly to the housing with the three screws provided.

13. Replace the left cover on the electronics housing. Fully engage.

Replacing The Transducer Assembly

Do not attempt to remove the transducer assembly from amplifier housing while transmitter is connected to the process. This procedure should be performed in the calibration shop. Remove amplifier board assembly before beginning this procedure.

Tools and materials required: Vise (soft jaws), 8-inch adjustable wrench, Loctite® Primer and Loctite Pipe Sealant.

1. Remove the support bracket and vibration insulators by removing the three hex head screws and washers.

2. Remove the anti-rotation bracket (see Figure 15) by removing two hex head screws and washers.

3. Be sure both covers are on the amplifier housing and are fully engaged, in order to protect threads on the amplifier housing.

4. Remove pipe plugs and/or conduit connections from amplifier housing (see Figure 7).

5. Secure transmitter in vise (with soft jaws).

6. With wrench, carefully loosen nipple (see Figure 15) from amplifier housing. **DO NOT LOOSEN OR REMOVE NIPPLE FROM TRANSDUCER ASSEMBLY.** Nipple and amplifier housing are assembled together using a sealing compound which must be broken loose.

7. Remove left amplifier housing cover so that sensor lead connector is visible.

8. Extreme care should be used in unscrewing transducer assembly from amplifier housing to avoid damaging sensor leads. Unscrew and remove transducer assembly from amplifier housing, rotating sensor leads as necessary to prevent twisting.

LOCTITE® is a registered trademark of Loctite Corp.

9. Mount replacement transducer assembly on pipe stand.
10. Clean threads on nipple and mating connection on amplifier housing.
11. Apply LOCTITE Primer NF and LOCTITE Pipe Sealant with TEFLON® #592 to threads on nipple according to Loctite instructions.
12. Carefully insert sensor lead wires with connector through mating hole in amplifier housing.
13. Thread amplifier housing onto nipple. Engage a minimum of seven full threads. While rotating housing, turn sensor leads as necessary to prevent twisting. Make sure that, in the fully engaged position, the high pressure pipe connection and the bottom support hole on the diaphragm assembly are in line (see Figure 15).

14. Cure in this position for 8 hours.
15. Remove transmitter from support bracket.
16. Attach anti-rotation bracket to rear cover using hex-head screws and washers provided. (see Figure 15).
17. Replace transmitter in support bracket.
18. Wrap threads on pipe plugs and/or conduit connections with one layer of TEFLON Tape Seal using a small overlap. Press tape seal into threads slightly to hold in place.
19. Replace plugs and/or conduit connections in amplifier housing and engage a minimum of five full threads.
20. Replace vibration insulators and support bracket using hex-head screws and washers provided.

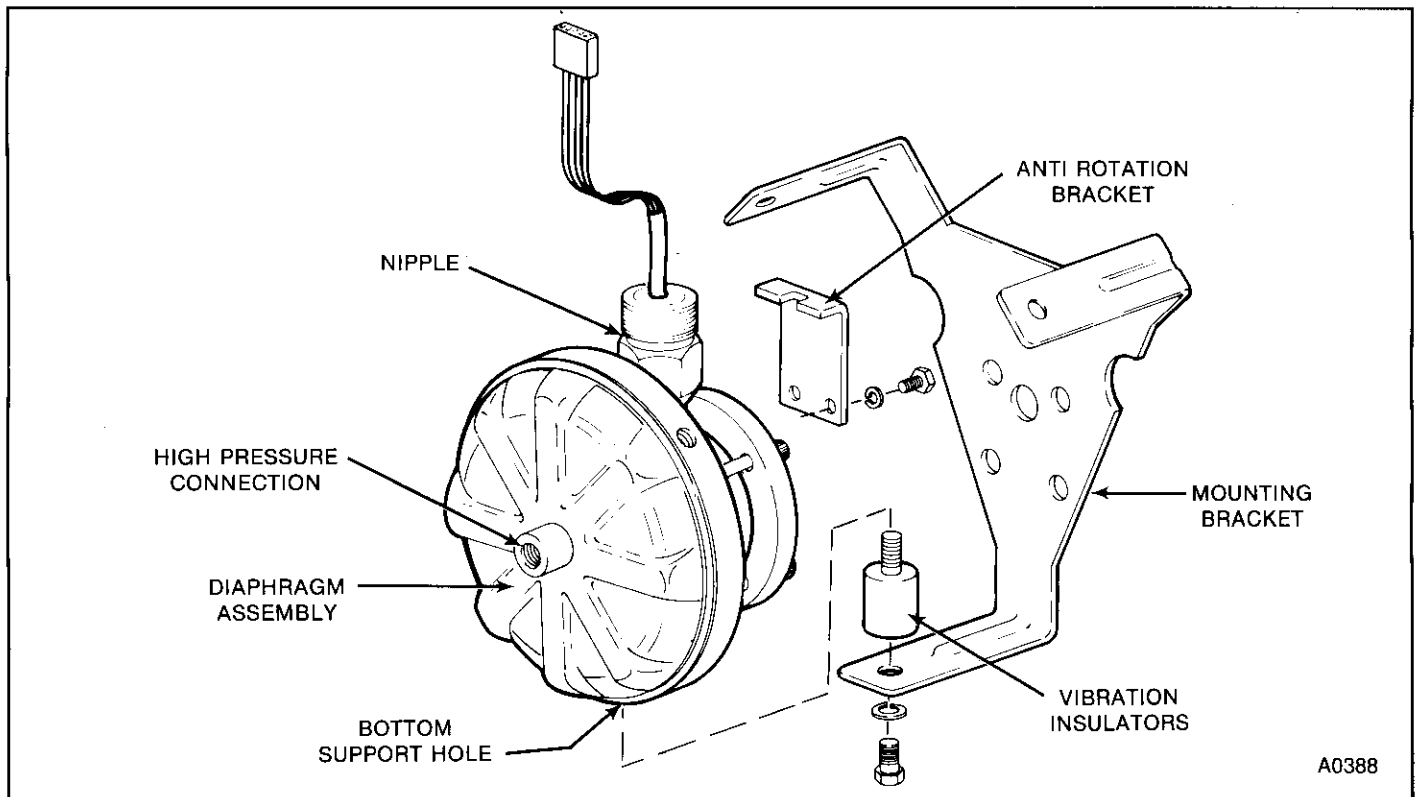

FIGURE 15 – Type BCNI Transducer Assembly

TEFLON® is a registered trademark of E.I. DuPont De Nemours.

Support Services

INTRODUCTION

This section provides an exploded view of the transmitter; its housing and amplifier assembly, along with the transducer assembly.

A parts list for the transmitter and associated spare parts kits are also provided.

REPLACEMENT PARTS

Mechanical hardware, base housings, covers, and mounting brackets are interchangeable among units without regard to range or calibration. Refer to Figure 16 for a Replacement Parts Drawing. Interchange of electronics and transducers is subject to the following conditions:

1. Amplifier circuit board assembly is interchangeable among units without regard to range. Any interchange of amplifier assemblies will require calibration of the new electronics.
2. Transducers are interchangeable, but calibration is required for both zero and span.
3. When either the amplifier assembly or the transducer is replaced, the temperature coefficients supplied with the transducer must be programmed into the electronics.

Support Services

PARTS LIST for FIGURE 16

ITEM	PART NO.	NAME
1	SEE TABLE 1	COVER
2	1948528_114	CONNECTOR ¹
3	6636084_1	LCD ASSY ¹
6	6634628_2	HOUSING, BASE
7	1951420_154	O-RING, SEAL (2 REQD)
8	6634668_1	FILTER ASSY (BLK)
9	6634668_2	FILTER ASSY (RED)
10	6634627_2	COVER ¹
11	1964021_1	LABEL
12	1946447_1	DIODE, SIG, SI, IN914B
—	6638009_1	AMPLIFIER ASSY (INCLUDES ITEMS 14-18)
14	6637783_1	MICROCOMPUTER BD ASSY
15	6637781_1	INPUT BD ASSY
16	6637779_1	COMMUNICATIONS BD ASSY
17	197729_4	STANDOFF (3 REQD)
18	197833_1	STANDOFF (3 REQD)
19	6633667_1	LOCKNUT ¹
20	6638057_1	LCD SUPPORT ¹
21	1948533_1	LUG (2 REQD)
22	1947411_1	CONNECTOR HEADER
23	6638062_1	SHIELD, LCD ¹
24	1951420_036	O-RING, SEAL ¹
25	199927_1	WINDOW ¹
26	197675_2	WASHER
27	1947784_4	TERMINAL BLOCK
28	6634662_1	SHIELD, TERM. BLOCK
29	195148_3	PLUG, PIPE
30	487436_2	TAG, STN. STL.
31	1944495_2	JUMPER
33	1963359_3	CSA, FM LABEL
34	1963318_[*]	NAMEPLATE
35	1963508_1	LABLE ¹
36	1963327_1	CALIBRATION LABEL
41	16349	1/2 IN. PULL PLUG
42	R2041-1650	22 AWG BLK LDWIRE (1.5 IN.)
43	R2041-1652	22 AWG RED LDWIRE (6.00 IN.)

ITEM	PART NO.	NAME
45	NDNAC12006	.138-32X .375 FIL HD SCREW (ROLOK)
46	NDOAC13012	.138-32X .750 FIL HD SCREW (ROLOK) (2 REQD)
47	NDOAC13014	.138-32X .875 FIL HD SCREW, (ROLOK) (3 REQD)
48	NHSHAO5004	.086-56X .250 STN STL SLTD PAN HD SCREW (2 REQD) ¹
49	NHSHAO9004	.112-40X .250 STN STL SLTD PAN HD SCREW, ¹
51	R6440-0005	.031 DIA. 347 STN STL WIRE (6.00 IN.)
52	NKJHA13004	.138-32x .250 STN STL SET SCREW ¹
54	6634409_1	KIT, MOUNTING (NOTSHOWN)
57	SEE TABLE 2	TRANSDUCER ASSEMBLY
58	6634371_1	VIBRATION INSULATOR (3 REQD)
59	NTJBC12030	.312 CD PL STL SPLIT SPRG LK WSHR (3 REQD)
60	NAUAC16006	.190-32x.375 HEX HD, CAP SCR (2 REQD)
61	6634060_1	WALL MTNG BRKT
62	NTJBC09030	.190 CD PL STL SPRG LK WSHR (2 REQD)
63	6634774_2	LOCKING BRKT
64	NAUAC23008	.312-18 CAP SCR, HEX HD (3 REQD)
65	NRSHA04003	.060-6)x .188 THRD FRMG SCR
66	R9910-0012	.007x 1.880 69-3M WHT GLASS CLOTH w/ SILICONE ADHESIVE TYPE E65 .460 ±.010 LG

¹BCN □□□□□□ 6 □

* Complete Part No. determined by origin of manufacture.

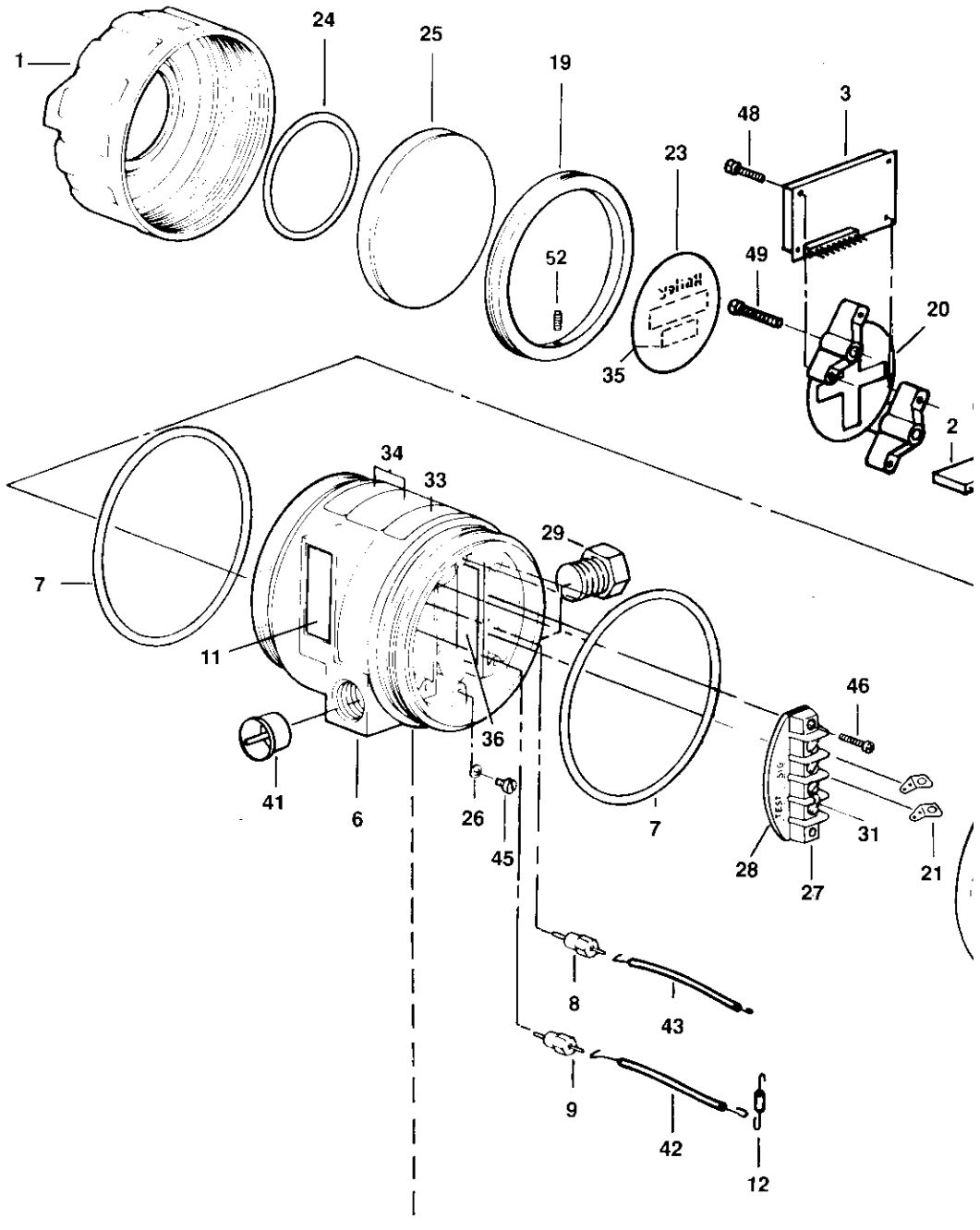

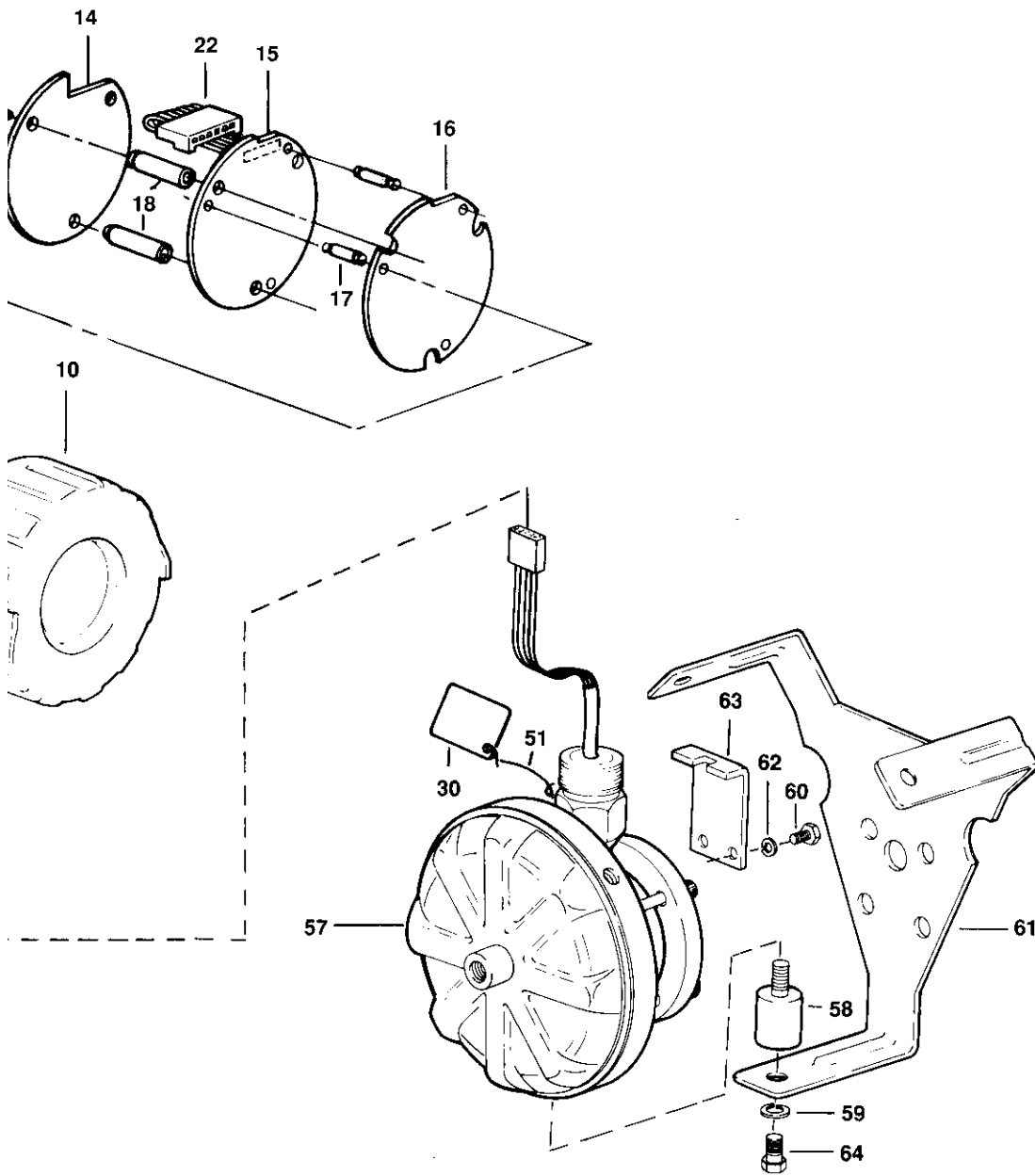

B0859

FIGURE 16 – Type BCNI Smart Transmitter Replacement Parts

Support Services

TABLE 1 – Left Housing Cover Part No.

NOMENCLATURE	METER	ITEM 1
BCN□□□□□5□	NONE	6634627_1
BCN□□□□□6□	LCD	6634627_2

TABLE 2 – TYPE BCN1 Transmitter/Transducer/Kit Cross Reference

NOMENCLATURE KIT NO.	TRANSDUCER PART NO.	TRANSDUCER (IN. H ₂ O)	SPAN		FILL FLUID	DIAPHRAGM MATERIAL
			ANALOG	DIGITAL		
BCN116113□0 126113□0	258299A1161-N A1261-N	663625A1161 A1261	0.5 – 3 1 – 6	0.3 – 3 0.6 – 6	SILICONE FLUID	316L SST
BCN116213□0 126213□0	A1162-N A1262-N	A1162 A1262	0.5 – 3 1 – 6	0.3 – 3 0.6 – 6	FLUORINATED OIL	

RECOMMENDED SPARE PARTS KITS

KIT NO. 258456_1 AMPLIFIER ASSEMBLY

ITEM NO.	PART NO.	NAME
14–18	6638009_1	AMPLIFIER ASSY
47	NDOAC13014	SCREW, 3 REQD
21	1948533_1	LUG, 2 REQD

KIT NO. 258453_1 LCD ADD-ON KIT ASSEMBLY (FOR BCN □□□□□6□)

ITEM NO.	PART NO.	NAME
1	6634627_2	COVER
2	1948528_114	CONNECTOR
3	6636084_1	LCD ASSEMBLY
55	6633667_1	LOCKNUT
20	6638057_1	LCD SUPPORT
23	6638062_1	LCD SHIELD
24	1951420_036	O-RING
25	199927_1	WINDOW
35	1963508_1	LABEL
48	NHSHA05004	SCREW, 2 REQD
49	NHSHA09004	SCREW, 2 REQD
52	NKJHA13004	SET SCREW

KIT NO. 258453_2 LCD REPLACEMENT ASSEMBLY (FOR BCN □□□□□6□)

ITEM NO.	PART NO.	NAME
3	6636084_1	LCD
2	1948528_114	CONNECTOR
20	6638057_1	LCD SUPPORT
23	6638062_1	LCD SHIELD
35	1963508_1	LABEL
48	NHSHA05004	SCREW, 2 REQD
49	NHSHA09004	SCREW, 2 REQD

KIT NO. 258461_□ AMPLIFIER PC BOARDS

KIT PART NO.	MICROCOMPUTER PC BD	INPUT PC BD	COMMUNICATIONS PC BD
258461_1	1 REQD	OMIT	OMIT
258461_2	OMIT	1 REQD	OMIT
258461_3	OMIT	OMIT	1 REQD

**KIT NO. 258283_1
COVER O-RING**

ITEM NO.	PART NO.	QTY.	NAME
7	1951420_154	10	O-RING

**KIT NO. 258286_1
MOUNTING BRACKET**

ITEM NO.	PART NO.	QTY.	NAME
61	6634060_1	1	MTG BRACKET
58	6634371_1	3	VIBRATION INSUL
59	NTJBCN12030	3	WASHER
64	NAUAC23008	3	SCREW

**KIT NO. 258299_1161-N
TRANSDUCER
(FOR BCN1161 □□5/6 □)**

ITEM NO.	PART NO.	QTY.	NAME
57	6636250_1161	1	TRANSDUCER ASSY
*	6634690_1	1	LOCKNUT
*	NKJMA21005	2	SCREW

**KIT NO. 258299_1261-N
TRANSDUCER (FOR BCN1261 □□5/6 □)**

ITEM NO.	PART NO.	QTY.	NAME
57	6636250_1261	1	TRANSDUCER ASSY
*	6634690_1	1	LOCKNUT
*	NKJMA21005	2	SCREW

**KIT NO. 258299_1162-N
TRANSDUCER (FOR BCN1162 □□5/6 □)**

ITEM NO.	PART NO.	QTY.	NAME
57	6636250_1162	1	TRANSDUCER ASSY
*	6634690_1	1	LOCKNUT
*	NKJMA21005	2	SCREW

**KIT NO. 258299_1262-N
TRANSDUCER (FOR BCN1262 □□5/6 □)**

ITEM NO.	PART NO.	QTY.	NAME
57	6636250_1262	1	TRANSDUCER ASSY
*	6634690_1	1	LOCKNUT
*	NKJMA21005	2	SCREW

* Items part of Item 57.

Appendix A

APPLICATIONS IN FLAMMABLE ATMOSPHERES

Hazardous Locations

The BCN Smart Transmitter is being evaluated for Factory Mutual Research (FM) approval and Canadian Standards Association (CSA) certification for use in flammable atmospheres as follows:

Nonincendive for: Class I; Division 2; Groups B,C,D

NOTE: "Nonincendive" implies the equipment will not ignite a specific hazardous atmosphere mixture under normal operating conditions.

Explosionproof for: Class I; Division 1; Groups B,C,D

Dust-ignitionproof for: Class II; Division 1; Groups E-G
Class III; Division 1

Intrinsically-safe for: Class I,II,III; Division 1; Groups A-G

Division 2 Applications Utilizing Nonincendive Rating

A Division 2 hazardous location is a location where a flammable substance is normally adequately contained or is normally adequately diluted by ventilation. A flammable or explosive concentration might occur due to a failure of containment or ventilation, however, such an occurrence would happen infrequently and for a short period of time. Containment failures could be due to leaking fittings, connectors, or seals. Guidelines for area classification are found in standards such as ANSI/NFPA 497A **Classification of Class I Hazardous (Classified) Locations for Electrical Installations in Chemical Process Areas.**

Nonincendive Equipment Rating

The incendive rating for the transmitter means that the unit has been evaluated to FM Class Number 3611 and CSA C22.2 No. 213 and has been found that under normal operation will not create a spark capable of igniting a specified test gas.

The T5 temperature message means that the BCN cannot be used with gases that have an autoignition temperature (AIT) less than 212°F (100°C). Auto ignition temperatures for many common gases and vapors can be found in ANSI/NFPA 497M "Classification of Gases, Vapors and Dusts for Electrical Equipment in Hazardous (classified) Locations."

WARNING

Disconnecting/reconnecting wiring or repairing the transmitter is not considered normal operation. These operations should only be done if power has been removed from all wiring or if the flammable atmosphere is known not to be present.

ATTENTION

Le débranchement ou le rebranchement des fils ainsi que la réparation du transmetteur n'entrent pas dans les procédures normales. Si l'atmosphère est inflammable, on ne doit effectuer les étapes ci-dessus que si l'alimentation a été interrompue.

Disconnecting the signal wiring connected to the transmitter would be permitted if the circuit is a Nonincendive Field Circuit. The National Electrical Code (NEC) refers to such a circuit as simply a Nonincendive circuit (since the NEC is an installation document, all references are to external circuits, e.g. field circuits) installed and tested while powered. Care must be taken to ensure that only one circuit is worked on at a time and that separate circuits are not shorted. Shorting of separate circuits is not part of the evaluation and could result in ignition capable arcs.

WARNING

Substitution of components may impair suitability for use in a hazardous location.

AVERTISSEMENT

La substitution de composants peut rendre ce matériel inacceptable pour les emplacements dangereux.

Wiring Requirements

Unless the current from the power supply is limited by series resistance, then the wiring must be suitable for a Division 2 hazardous location. The National Electrical Code requires the use of rigid metal conduit or non-metallic cable certified as "HL".

Appendix A

PLTC cable is rated 300 V and can be obtained in wire sizes 22 AWG to 16 AWG at various temperature ratings. This would be the recommended wiring for transmitters installed in the United States.

Nonincendive Field Circuits

If it is desired to use ordinary location wiring for the circuit or if it is desired to service individual transmitters while they are powered, then the power source must be voltage and current limited such that opening, shorting, or grounding of the circuit will not cause an ignition capable arc. In addition, operating on live circuits should only be done if there is not a shock hazard. For dry locations, the voltage should be less than 42 V dc or 30 V ac.

The documents listed at the end of this Appendix provide ignition curves to provide guidelines for limiting voltage and current. In general, there are three criteria:

1. For a given open circuit voltage, adequate series resistance must be provided at the power source to limit the short circuit current.
2. For given open circuit voltage, the capacitance of the transmitter plus cable must not exceed a specific value.
3. For a given short circuit current, the inductance of the transmitter plus cable must not exceed a specific value.

Any wiring type may be used for nonincendive field circuits per the exception in the NEC article 501-4 (b) and CEC article 18-066 (2).

Applicable Standards

The following standards are available for designing and installing nonincendive circuits and equipment:

ANSI/ISA RP12.6-1988 "Installation of Intrinsically Safe Systems for Hazardous (Classified) Locations".

Instrument Society of America
67 Alexander Drive
P.O. Box 12277
Research Triangle Park, NC 27709

ANSI/ISA S12.12-1984 "Electrical Equipment for use in Class I, Division 2 Hazardous (Classified) Locations".

Instrument Society of America
67 Alexander Drive
P.O. Box 12277
Research Triangle Park, NC 27709

CSA C22.2 No. 213-M1987 "Non-Incendive Electrical Equipment for use in Class I, Division 2 Hazardous Locations".

Canadian Standards Association
178 Rexdale Boulevard
Rexdale (Toronto), Ontario Canada M9W 1R3

UL 1604 (1982) "Electrical Equipment for use in Hazardous Locations".

Underwriters Laboratories
333 Pfingsten Road
Northbrook, ILL. 60062

FM Class Number 3611 (1986) "Electrical Equipment for use in Class I, II Division 2; Class III, Division 1 and 2 Hazardous Locations".

Factory Mutual Research
1151 Boston-Providence Turnpike
Norwood, Mass 02062

INTRINSIC SAFETY APPLICATIONS

Bailey Controls Technical Guide TG999-13 contains information for determining minimum power supply voltage for performance of a 4 to 20 mA loop when various intrinsic barriers are used.

WARNING

Intrinsic safety is dependent upon the components used in the transmitter. Any substitution of components may impair the intrinsic safety.

AVERTISSEMENT

La securite intrinseque depend des composantes utilisees dans l'emetteur. Toute substitution de composante pourrait nuire a cette securite intrinseque.

FACTORY MUTUAL (FM)

Factory Mutual (FM) approved with entity rated barriers that do not exceed 40 volts (Voc) and 332 mA (Isc) (See Figure A1).

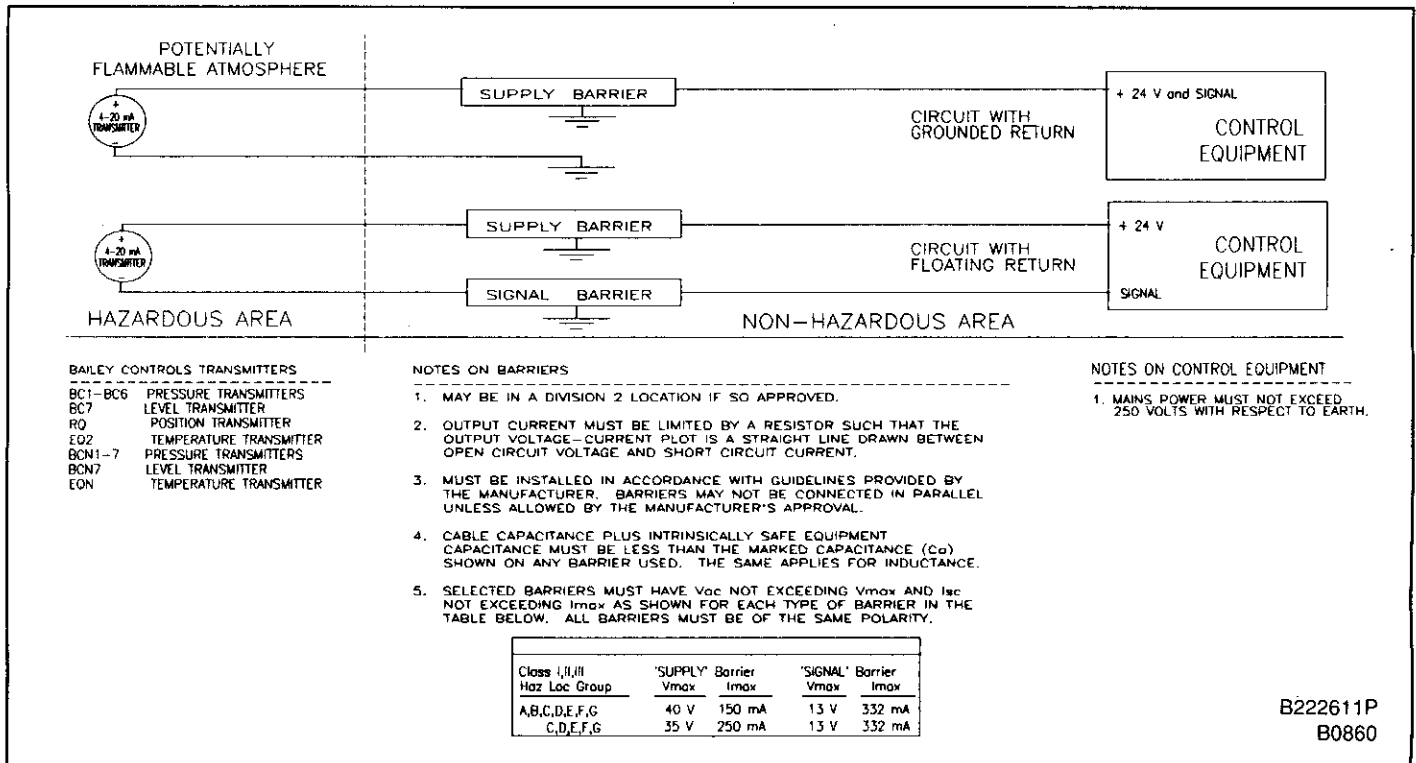

FIGURE A1 - Loop Drawing

FIGURE	BAILEY FIELD EQUIP.	HAZARDOUS LOCATION	FIGURE(S)	PARAMETERS CERTIFIED BY CANADIAN STANDARDS ASSOCIATION															
				BARRIER PARAMETERS FOR GROUPS A TO G								BARRIER PARAMETERS FOR GROUPS C TO G							
				10V	12V	20V	22V	25V	28V	29.5V	30V	32V	10V	12V	27V	28V	30V	33V	
FIGURE 1	KA	ABCD EFG	yes	1	40 Ω						240 Ω		250 Ω		40 Ω			150 Ω	
FIGURE 2	EQ10	ABCD EFG	yes	1	40 Ω					240 Ω		250 Ω		40 Ω				120 Ω	150 Ω
	EQ2	ABCD EFG	yes	2	40 Ω		150 Ω		270 Ω			400 Ω		40 Ω	120 Ω			150 Ω	
	EQN	ABCD EFG	yes	3	40 Ω		150 Ω	200 Ω	270 Ω	305 Ω		400 Ω		40 Ω		120 Ω		150 Ω	200 Ω
FIGURE 3	BC	ABCD EFG	yes	1 & 2	40 Ω		150 Ω		270 Ω			400 Ω		40 Ω	120 Ω			150 Ω	
	BCN	ABCD EFG	yes	3	40 Ω		150 Ω	200 Ω	270 Ω	305 Ω		400 Ω		40 Ω		120 Ω		150 Ω	200 Ω
	RO	ABCD FG	yes	1	40 Ω		100 Ω		240 Ω		300 Ω		40 Ω		120 Ω			150 Ω	
	AP54	ABCD	no	4	40 Ω				240 Ω		250 Ω		40 Ω		150 Ω				
FIGURE 4	AP73	ABCD	no	4	40 Ω		150 Ω	200 Ω	270 Ω			400 Ω		40 Ω		120 Ω	150 Ω	200 Ω	
	AP83	ABCD	no	1 & 5	40 Ω		150 Ω	200 Ω	270 Ω			400 Ω		40 Ω		120 Ω	150 Ω	200 Ω	
	STT02	ABCD EFG	yes	2 & 3	40 Ω		150 Ω	200 Ω	270 Ω	305 Ω		400 Ω		40 Ω		120 Ω	150 Ω	200 Ω	

TABULATION SHOWS ALLOWED COMBINATION OF BARRIER VOLTAGE AND RESISTANCE RATINGS.

FOR ANY COMBINATION, THE SELECTED BARRIER MUST NOT HAVE A VOLTAGE RATING EXCEEDING THE TABULATED VALUE NOR HAVE A RESISTANCE RATING LESS THAN THE TABULATED VALUE.

SIGNAL BARRIERS MUST NOT EXCEED 12 VOLT RATING OR BE DIODE RETURN TYPE BARRIER.

B222611P
B0861

FIGURE A2 - CSA Certified I.S. Entity Loops

Appendix A

Canadian Standards Association (CSA)

CSA certification pending with any certified barrier which does not exceed the following parameters:

VOLTAGE (MAXIMUM)	GROUPS A-G RESISTANCE (MINIMUM)	GROUP C-G RESISTANCE (MINIMUM)
32 volts	400 ohms	—
30 volts	—	150 ohms
28 volts	270 ohms	—
27 volts	—	120 ohms
22 volts	150 ohms	—
12 volts	40 ohms	40 ohms

Manufacturers with CSA certified barriers include Bailey Controls, Beckman, MTL, Stahl, and Taylor.

Generals Requirements

Any intrinsically safe installation must be done in accordance with barrier manufacturer's instructions. ISA RP12.6 "Installation of Intrinsically Safe Systems in Hazardous (Classified) Locations" also provides detailed recommendations for installing equipment and wiring in intrinsically safe loops. The essential parts of a proper installation are:

1. Mounting barriers and field equipment only in flammable atmosphere for which they are specified.
2. Segregation of intrinsically safe wiring to prevent contact with other circuits.
3. Grounding of non-isolating intrinsic safety barriers.
4. Verifying that Control Room equipment does not contain voltages above 250 V ac unless suitably certified to limit the voltage to barriers.
5. Verifying that enclosures are properly sealed when used in Class II and Class III hazardous locations (see **WARNING** under **Explosionproof/Dust-ignition-proof**).

WARNING

Substitution of components may impair suitability for use in a hazardous location.

AVERTISSEMENT

La Substitution de composants peut rendre le positionneur inadquat a l'utilisation dans un environnement dangereux.

Explosionproof/Dust-Ignitionproof

A proper explosion proof installation must comply with national codes such as NFPA 70 (ANSI C1) and local regulations for electrical installations in hazardous locations. The essential parts of such an installation are:

1. All tapered conduit connections must be made with at least five fully engaged threads.
2. All unused conduit openings must be closed by a 1/2-inch NPT pipe plug with at least five fully engaged threads.
3. The enclosure covers must be fully threaded on the enclosure with at least seven fully engaged threads.
4. All conduit connections must be properly sealed no farther than 18 inches (45 cm) from the enclosure.
5. Tapered threaded connections (such as pipe plugs and thermowells) must engage at least five full threads.

WARNING

Explosionproof/dust-ignition proof installation and intrinsically safe installations in Class II or III hazardous locations require that the assembly be kept tight while circuits are live unless the location is known to be non-hazardous at the time.

AVERTISSEMENT

En ce qui concerne l'installation anti-explosion et anti-ignition provoquee par la poussiere dans des endroits se Classe II ou III, il est indispensable que l'assemblage soit tenu etanche pendant que les circuits sont electrises, a moins que cet endroit ne presente aucun danger a ce moment-la.

E21-31 Type BCN1 Smart Electronic Pressure Transmitter

For a complete list of licensees, representatives and affiliates in over 50 countries worldwide, contact . . .

Bailey Controls Company

29801 Euclid Avenue, Wickliffe, Ohio 44092 • (216) 585-8500
Telex: 980621 • Telefax: (216) 585-8756 or (216) 943-4609